

Twin Cylinder Crushing Cutter PAT

DX-SRC Crushing Cutter

DX-SRC-72AS | DX-SRC-135S/A/AS | DX-SRC-212S/A/AS | DX-SRC-352S/A/AS

Operation & Maintenance Manual



Warning

- Inappropriate use of this product may lead to a serious accident.
- Operators and service representatives must carefully read and sufficiently understand this manual before operating, inspecting, or maintaining this product.
- Always store this manual nearby and read it repeatedly.
- This manual covers only this product (attachment). When you operate the attachment, read the Operation & Maintenance Manual of the hydraulic excavator (base machine) together with this manual.
- **Note that the warranty does not cover damages caused by the use of non-genuine parts.**

TAGUCHI®

Before reading this manual

Thank you for purchasing this product.

This manual contains operation, inspection, and maintenance procedures of this product (attachment) and items that must be strictly observed so you can use this product safely. Many accidents occur due to operation, inspection, and maintenance that do not observe basic precautions.

Before operating, inspecting, or maintenance this product, read and understand all warnings and preventative measures of this product and this manual. If warnings and preventative measures are not observed, serious injury or death may result.

This product is attached to hydraulic excavators of various manufacturers. When you work with this product (perform attachment work), use the manual of the hydraulic excavator and this manual.

Taguchi cannot predict all conditions under which the customer will use this product. Therefore, the precautions listed in this manual and safety marks displayed on products do not cover all circumstances related to safety. Accordingly, if operation, inspection, and maintenance will be performed under circumstances not written in this manual, the customer is responsible for all preventative measures necessary for safety. Furthermore, in such cases, never perform operations or work prohibited by this manual. Incorrect operation, inspection, and maintenance of products are dangerous and may lead to serious injury or death.

Persons involved in the handling of this product must read this manual carefully and understand its content before carrying out work. This includes hydraulic excavator operators (with qualifications), work managers, work directors, and staff that perform onsite attachment exchange, transfer (shipping), maintenance, inspection, and repair (gas welding work managers).

If this manual is lost, damaged, or becomes illegible due to soiling, contact your Taguchi dealer immediately and arrange for a replacement. To ensure that the correct manual is delivered, confirm the serial number of this product before contacting your Taguchi dealer.

Always store this manual in the manual storage location shown below so that authorized people can reference this manual repeatedly and as needed.

If this product will be resold or transferred to a third party, pass this manual to the new owner.

Manual storage location

Magazine box ►

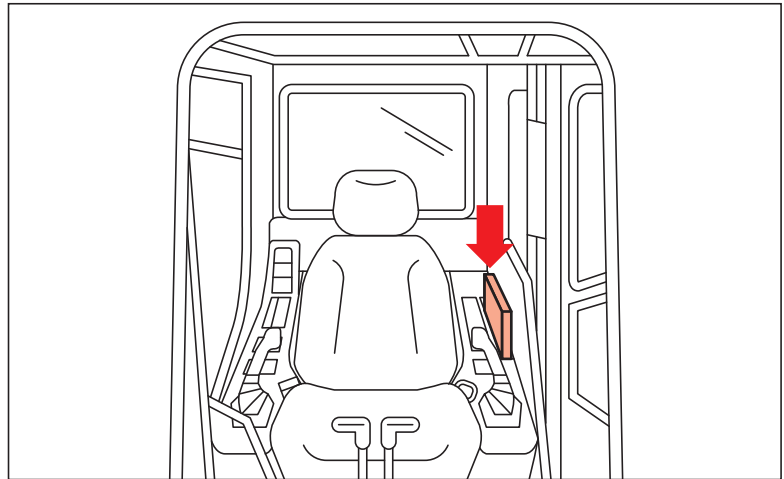

If the safety decals affixed to this product come off or become illegible due to soiling, contact your Taguchi dealer immediately to replace them with new ones.

The explanations, numerical values, illustrations, and other components of this manual are based on information available at the time this manual was created. Due to Taguchi's policy of constantly improving product quality, the product you are using may differ partially with the information and product specifications listed in this manual. If you have any questions or comments about this manual, please contact your Taguchi dealer.

Taguchi has the right to change material and specifications to this product at any time without notice. Furthermore, Taguchi has the right to stop production of any product at any time at its own discretion.

Using machinery safely

To prevent accidents resulting in personal injury or death of people performing operation, inspection, or maintenance, and for the safety of people around machinery, always observe the warnings and protective measures displayed in this manual and on the product.

The following signal words are used to classify important safety messages in safety marks displayed in this manual and on products.

Safety alert symbols are used to identify important messages on this product and in this manual. These alert symbols list the danger of accidents that lead to injury or death. Always follow these safety alert symbols.



Danger

Indicates an imminently hazardous situation that will very likely lead to death or serious injury if not avoided.



Warning

Indicates a potentially hazardous situation that may lead to death or serious injury if not avoided.



Caution

Indicates a potentially hazardous situation that will lead to a slight or moderate injury if not avoided.

As another signal word, the following symbol indicates actions that should always be observed to prevent machine damage.

Notice

If the displayed notice is not observed, the product may be damaged or its lifespan may be reduced.

Intended use

Use this product primarily for the following work.

- Dismantling of steel reinforced concrete structures
- Demolition and crushing of concrete and asphalt
- Cutting of rebar

Do not use this product for other uses.

Operation qualifications

Operators of a hydraulic excavator with this product attached may be required to take a course, such as skill training course for operation of vehicle type construction machine, and have evidence of course completion as prescribed by Industrial Safety and Health Act and related laws and regulations.

Product serial numbers, nameplates, and safety decals

Notice

The product serial number is engraved and nameplates and safety decals are affixed to the body of this product. Check the nameplates for the model name, mass, and year of manufacture of this product.

Warning

As listed on the safety decals affixed to the body of this product, you must read this manual carefully and sufficiently understand the correct operation, inspection, and maintenance methods before operation.

Failure to follow this manual may lead to a serious accident or loss.

(Example) In case of DX-SRC-212A

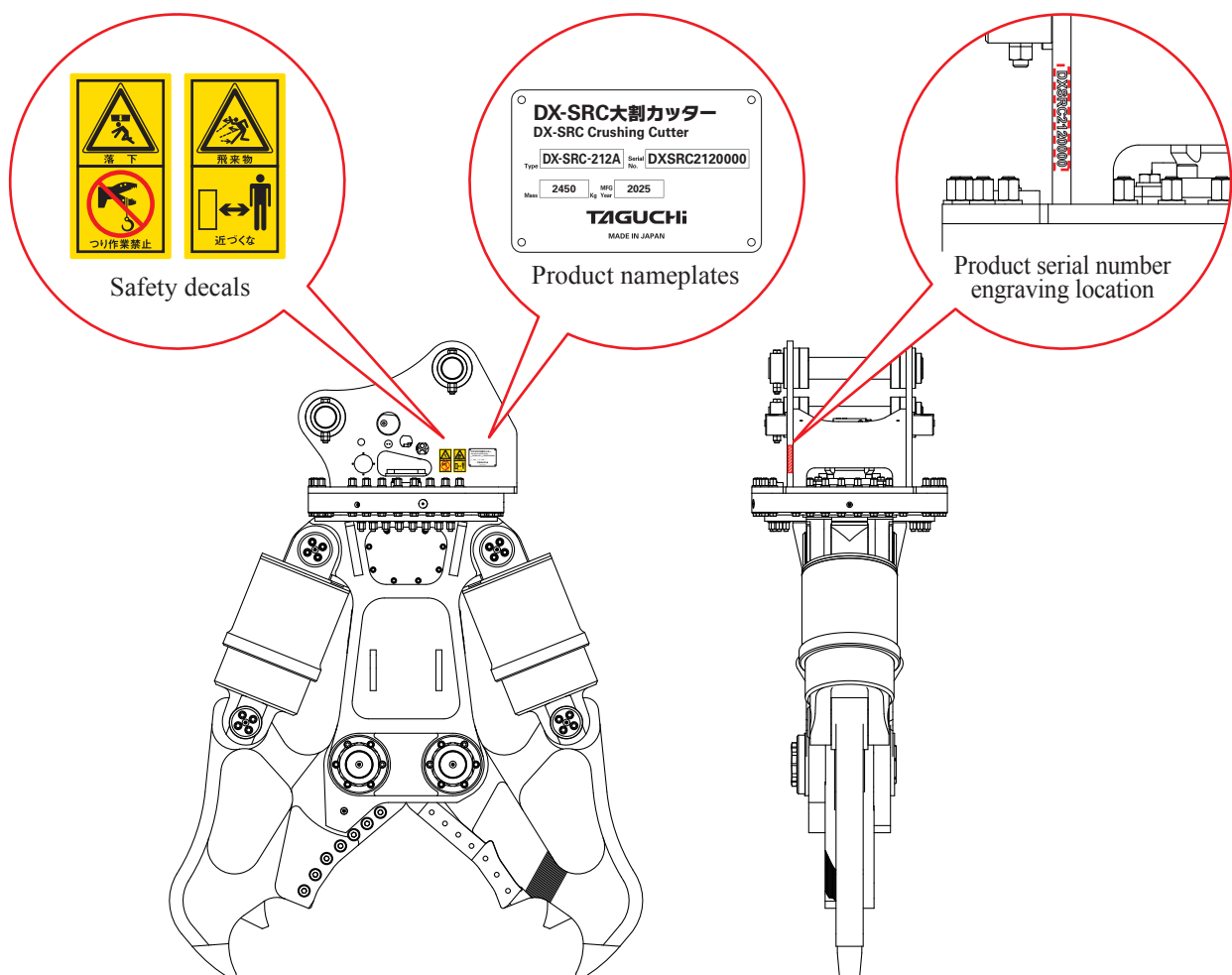

Note: The locations of the nameplate and caution plate differ by model.

When communicating orders or failure of parts, provide the product model name and product serial number to your Taguchi dealer.

MEMO

▶-----◀

▶-----◀

▶-----◀

▶-----◀

Contents

| | |
|--|----------|
| Before reading this manual | 2 |
| Using machinery safely | 4 |
| Intended use | 5 |
| Operation qualifications | 5 |
| Product serial numbers, nameplates, and safety decals | 6 |

Safety 11

| | |
|--|-----------|
| 1. Precautions | 12 |
| 1-1 Observe the basic safety rules | 12 |
| 1-2 Always install safety devices | 12 |
| 1-3 Wear proper clothing and protective equipment | 13 |
| 1-4 Install on a compatible hydraulic excavator | 13 |
| 1-5 Use genuine parts | 14 |
| 1-6 Do not modify | 15 |
| 1-7 Read safety decals (caution plates) carefully | 15 |
| 1-8 Precautions when installing and removing | 15 |
| 1-9 Check for interference with excavator body | 17 |
| 1-10 Check the connection positions of the hydraulic hoses | 18 |
| 1-11 Check the opened/closed state of the stop valves | 18 |
| 2. Work cautions | 19 |
| 2-1 Do not enter within the working range | 19 |
| 2-2 Check the withstand load of the floor | 19 |
| 2-3 Work in the direction of the crawler tracks | 19 |
| 2-4 Watch for falling objects | 19 |
| 2-5 Do not approach a hydraulic excavator in operation | 20 |
| 2-6 Do not perform work in which the hydraulic excavator rises from the ground | 20 |
| 2-7 Do not operate on unstable surfaces | 20 |
| 2-8 Operator must be trained and qualified | 20 |
| 2-9 Use a signal before starting the engine | 21 |
| 2-10 Keep away from high-voltage cables | 21 |
| 2-11 Maintain sufficient visibility | 22 |
| 2-12 Cautions about slopes..... | 22 |
| 2-13 Watch for collisions..... | 23 |
| 2-14 Do not perform excessive work | 23 |
| 2-15 Do not use the attachment to crush fieldstone..... | 25 |

| | |
|---|-----------|
| 2-16 Use the cutting blade to cut only rebar and steel frames | 25 |
| 3. Cautions while travelling | 26 |
| 3 Cautions while travelling | 26 |
| 4. Cautions after operation | 27 |
| 4-1 Cautions when leaving the driver's seat..... | 27 |
| 4-2 Safely store the attachment | 27 |
| 4-3 Maintenance position | 28 |
| 4-4 Managing hydraulic oil | 29 |
| 4-5 Watch for high-pressure oil | 30 |
| 4-6 Watch for fire and explosions..... | 30 |

Operation **31**

| | |
|---|-----------|
| Specifications and Dimensions..... | 32 |
| Hydraulic rotation type (S type) | 32 |
| Automatic rotation type (A type)..... | 33 |
| Automatic/hydraulic rotation type (AS type)..... | 34 |
| Component names | 35 |
| Hydraulic rotation type (S type) | 35 |
| Automatic rotation type (A type)..... | 36 |
| Automatic/hydraulic rotation type (AS type)..... | 37 |
| Inspections and preparation before operation..... | 38 |
| Inspections | 38 |
| Preparation..... | 38 |
| Switching between automatic rotation and hydraulic rotation mode (AS type)..... | 39 |
| Switching between A/S modes..... | 40 |
| Operation control..... | 43 |
| Hydraulic rotation type (S type) and automatic/hydraulic rotation type (AS type: S mode) | 43 |
| Automatic rotation type (A type) and automatic/hydraulic rotation type (AS type: A mode) | 44 |
| Installing the attachment | 46 |
| Greasing..... | 53 |
| Lubrication points..... | 54 |
| Warm-up operations..... | 58 |
| Adjusting the rotation speed of the attachment (S type, AS type: S mode) | 59 |

| | |
|--|----|
| Troubleshooting during attachment installation | 60 |
| Removing the attachment | 61 |

Inspection and Maintenance 65

| | |
|--|-----------|
| Releasing internal pressure of hydraulic circuit to prevent high-temperature/high-pressure oil spouting | 66 |
| Internal pressure release procedure | 66 |
| Retightening of bolts, nuts, and hydraulic hoses | 67 |
| Retightening examples | 67 |
| Adjusting the gap of the jaw of the attachment | 69 |
| Adjusting using the nuts | 69 |
| Inspecting the cutting blades | 71 |
| Wear limit of cutting blade (bottom side) | 71 |
| Wear limit of cutting blade (tip side) | 72 |
| Adjusting the gap of the cutting blades | 73 |
| Repair welding | 75 |
| Repairing teeth | 75 |
| Buildup repair of worn areas | 76 |
| Storage | 79 |
| Cautions during transport | 80 |
| Lifting the attachment | 80 |
| Periodical maintenance | 81 |
| Troubleshooting | 84 |
| Standard torque table | 86 |
| Hydraulic hose coupling tightening torque table | 87 |
| LIMITED PRODUCT WARRANTY | 88 |

Safety

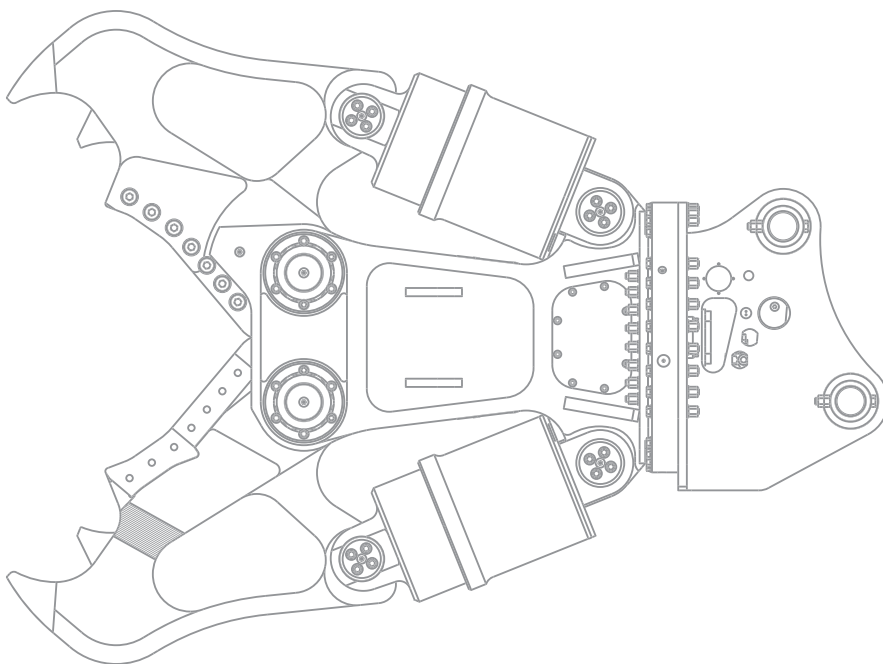

Warning

Fully understand the safety precautions displayed in this manual and on the product.

Strictly observe the precautions when operating, inspecting, or maintaining this product.

1. Precautions

Warning

1-1 Observe the basic safety rules

Operators of a hydraulic excavator with this product attached may be required to take a course, such as skill training course for operation of vehicle type construction machine, and have evidence of course completion as prescribed by Industrial Safety and Health Act and related laws and regulations.

- The attachment must be maintained by a person that has received education and training related to machinery. If a person without sufficient knowledge carries out maintenance, a breakdown or damage may occur.
- Observe all safety regulations, precautions, and procedures when operating or maintenance machinery.
- When performing group work or when a leader has been fixed, work based on established signals.

1-2 Always install safety devices

- During attachment work, there is a chance that falling or scattered objects may enter the operator cab. To protect the operator, install a front guard, head guard, and top guard and affix a laminate coating sheet to the windshield.

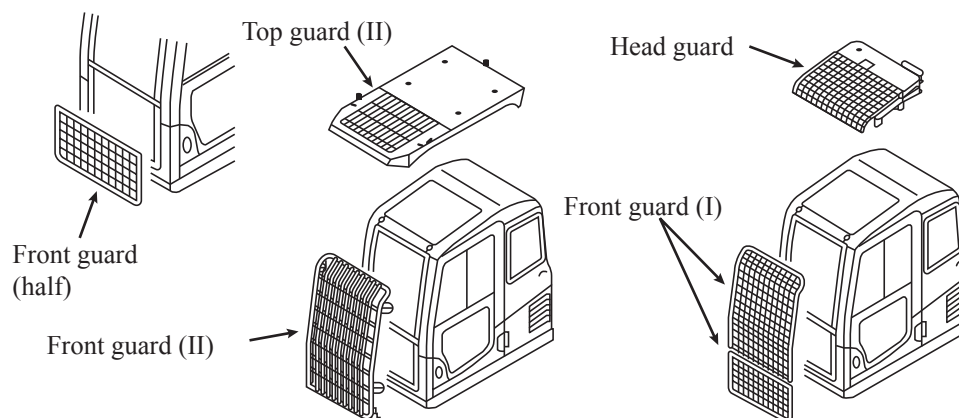

- When you are working in a location with a risk of falling rocks, such as during bedrock excavation at a stone pit or tunnel construction, install a FOPS (falling object protective structure) on the hydraulic excavator and affix a laminate coating sheet to the windshield.
- When working, always close the front window of the hydraulic excavator.
- During attachment work operation, make sure that other people stay a reasonable distance away so that falling objects and scattered objects cannot reach them.

Warning

1-3 Wear proper clothing and protective equipment

- Do not wear loose clothing, jewelry, or other decorative items that may be caught by control levers or mechanical parts. This may cause the machinery to malfunction. Furthermore, never wear work clothes stained with oil, as they can catch fire easily. Make sure to wear protective gear to prevent from burning, especially during welding works.



- Always wear a helmet and safety footwear. Wear safety glasses, a mask, gloves, hearing protection, a safety belt, and other protective equipment as required by the work. Particularly when there is a danger of flying metal pieces or foreign substances, such as when hammering a pin with a hammer, always wear protective equipment. Furthermore, always make sure that there are no people around before starting work.

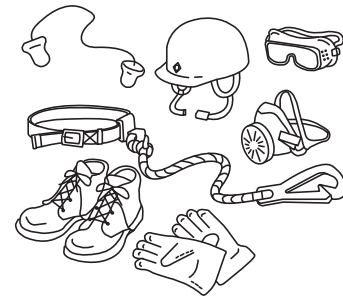

1-4 Install on a compatible hydraulic excavator

Always use an attachment model that suits the hydraulic excavator. If the hydraulic excavator is small, there is a risk that it will lose balance and fall over. If the hydraulic excavator with the product is larger than our recommendations, some unintended external force may be given to the product and it will cause machine breakdown. Please consult your Taguchi dealer about the hydraulic excavator class to attach the product.

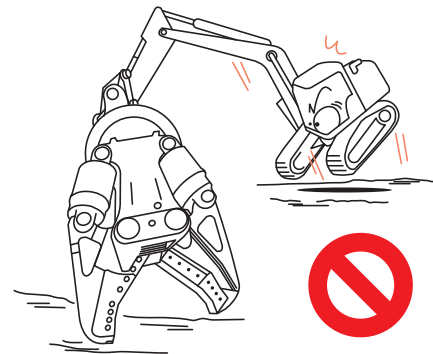

 **Danger****1-5 Use genuine parts**

- Always use genuine parts when replacing parts.

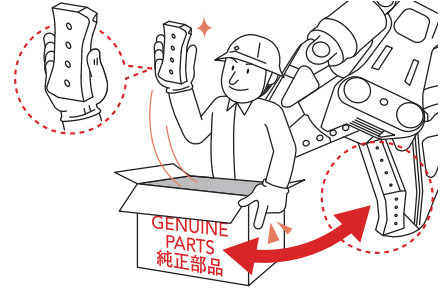

- Use of non-genuine parts may result in accidents or attachment damage due to interference, insufficient strength, or other part problems.

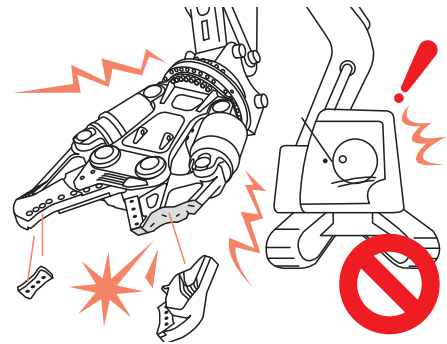

Warning

1-6 Do not modify

- Only make modifications recommended by Taguchi. Otherwise, safety problems may occur.
- If modification is unavoidable, always contact Taguchi or your Taguchi dealer in advance.

1-7 Read safety decals (caution plates) carefully

- Carefully read and understand the safety decals affixed to the hydraulic excavator and attachment.
- Always keep safety decals clean. If safety decals are lost or damaged, affix them again or contact your Taguchi dealer and replace the safety decals with new ones.

1-8 Precautions when installing and removing

When installing and removing the attachment, observe the following precautions and work safely.

- Carry out installation and removal on flat solid ground. Always place a stand, rectangular lumber, or other similar item on a solid flat surface, place this product on it, and then stabilize the product.

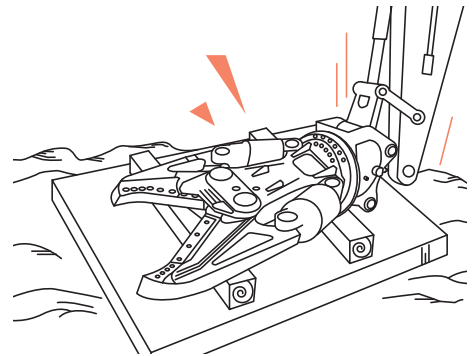

- When two or more people are working together, follow established signals.



- When carrying heavy items (25 kg or greater), use a crane.

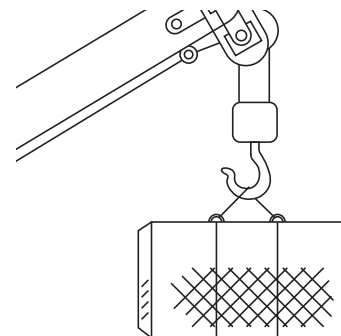

 **Warning****1-8 Precautions when installing and removing**

- When removing heavy parts, always use a support before removal. Furthermore, when hanging objects by a crane, etc., pay particular attention to the location of the center of gravity.

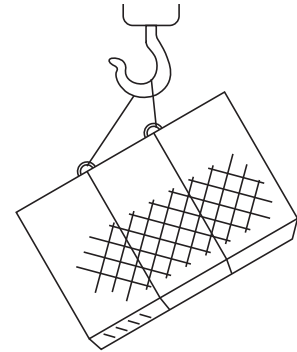

- Working while a part or the attachment is still suspended by a crane is dangerous. Always use a stand and ensure safety before starting work.

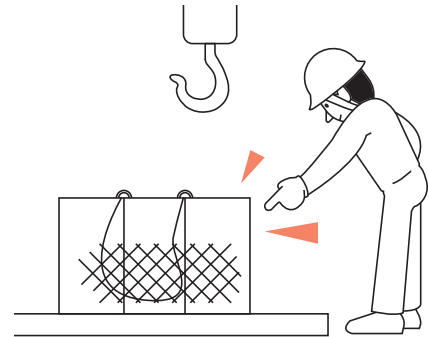

- Never stand under an item suspended from a crane. Stay back in a risk-free, safe location in the unlikely event that an object falls.



- For details of installation and removal, see “Installing the attachment” (P.46) and “Removing the attachment” (P.61) in the Operation section.

 **Warning****1-9 Check for interference with excavator body**

- There may be interference with the excavator body (operator cab, boom hydraulic cylinder, or undercarriage) depending on the operation method or attachment type.



- When operating an attachment or working equipment (boom and stick), take sufficient care not to hit the excavator body.

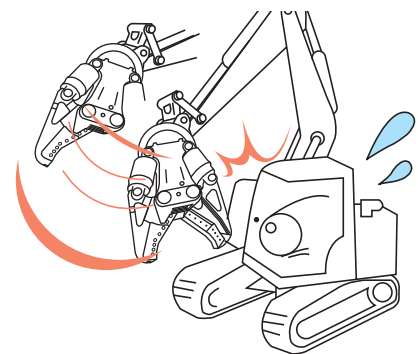

- After installing the attachment, always check for interference and the range of work in a risk-free environment.

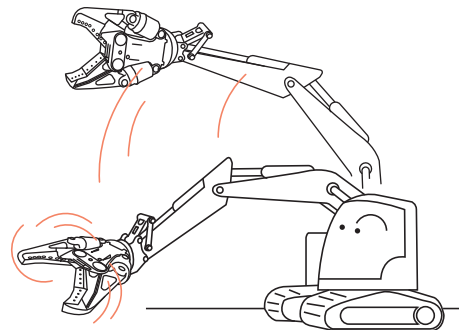

Notice

1-10 Check the connection positions of the hydraulic hoses

Always confirm the piping pattern with the hydraulic-excavator manufacturer. Connect the connection hydraulic hoses correctly to the specified positions on the attachment and hydraulic excavator.

The hydraulic motor inside the attachment will be damaged particularly if the connection location of the drain hydraulic hose was incorrect.

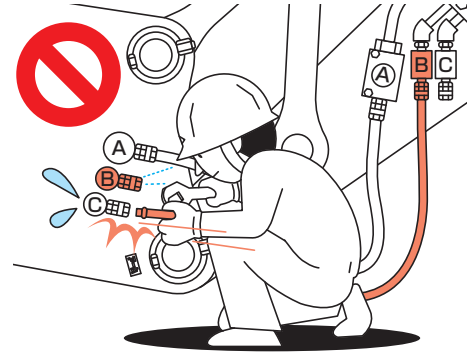

1-11 Check the opened/closed state of the stop valves

Make sure the stop valves of hydraulic excavator that are connected to the attachment are fully open (ON).

If the attachment is used while the stop valves are fully closed or half closed, the attachment may be damaged.

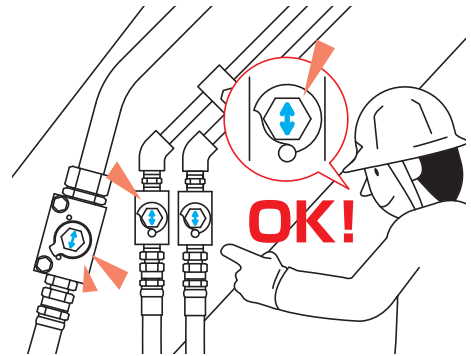

2. Work cautions

Danger

2-1 Do not enter within the working range

Do not enter into or place your hands, arms, or other body parts in the working range. Furthermore, do not stand or place your hands, arms, or other body parts directly under the attachment or hydraulic excavator. An operation of the hydraulic excavator may cause death or serious injury. For example, be aware that an accident may occur due to an internal leak of the hydraulic cylinder, even when the engine is stopped.

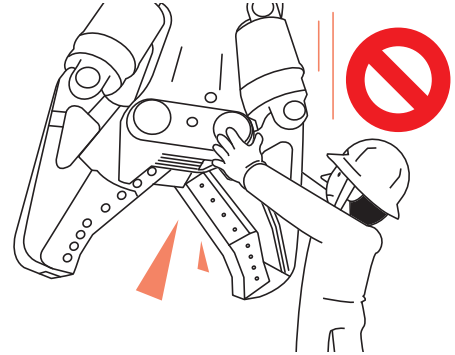

2-2 Check the withstand load of the floor

When you are working inside a building, make sure that the withstand load of the floor is sufficiently safe. The floor may fall out during work or a load greater than the weight of the machine may be applied to the floor surface depending on the work methods, which is very dangerous.

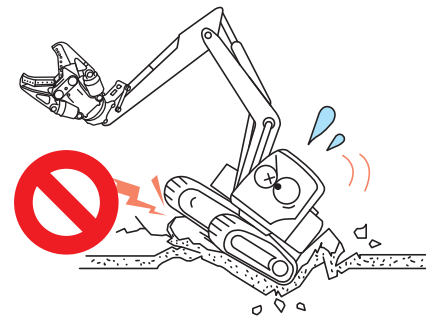

2-3 Work in the direction of the crawler tracks

Depending on the work methods, working crosswise to the crawler tracks can cause instability, which is very dangerous. Take care when working crosswise to the crawler tracks.

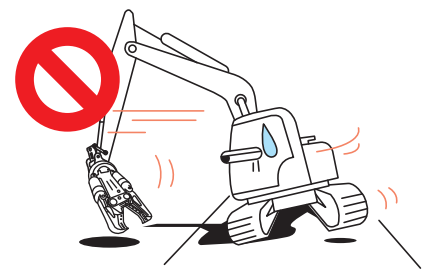

2-4 Watch for falling objects

When you demolish a structure, work so that items such as beams, pillars, and concrete do not fall from above the operator.

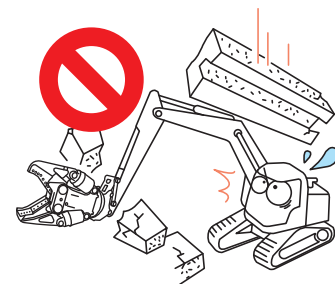

Danger

2-5 Do not approach a hydraulic excavator in operation

The area around an attachment or hydraulic excavator in operation is very dangerous. Never approach an attachment or hydraulic excavator in operation.

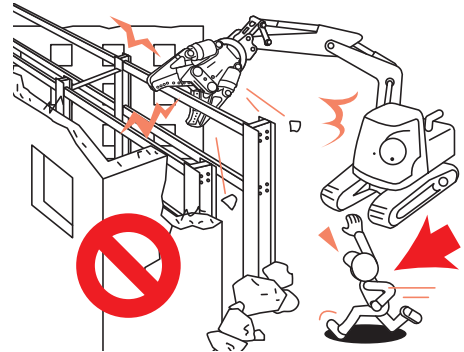

2-6 Do not perform work in which the hydraulic excavator rises from the ground

Do not use the weight of the hydraulic excavator such that it rises from the ground.

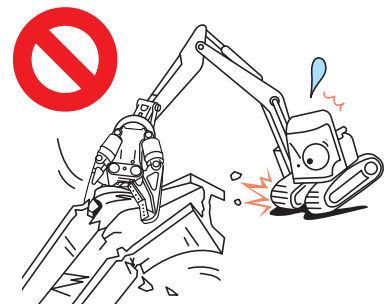

2-7 Do not operate on unstable surfaces

While you work, keep the hydraulic excavator body level and its base stable. Riding on crushed material and working on slopes are particularly dangerous.



Warning

2-8 Operator must be trained and qualified

Operators of a hydraulic excavator with this product attached may be required to take a course, such as skill training course for operation of vehicle type construction machine, and have evidence of course completion as prescribed by Industrial Safety and Health Act and related laws and regulations (P.5 “Operation qualifications”).

 **Warning**

2-9 Use a signal before starting the engine

- Always make sure that there are no people around the excavator body or in the work area before getting on the excavator.

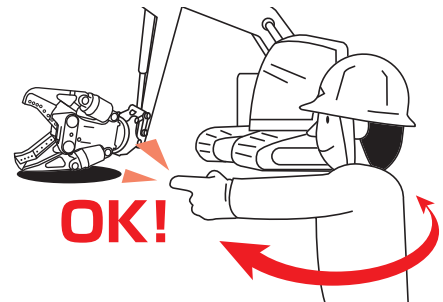

- When starting the engine, sound the horn first as a warning.

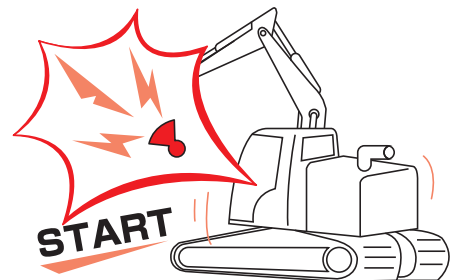

- Do not allow people other than the operator to get on the excavator body or in the operator's cab.



2-10 Keep away from high-voltage cables

Simply approaching high-voltage cables can result in electric shock. Be familiar with the maximum height of the excavator body and the maximum attained height of the working equipment (boom and stick) including the attachment, and always maintain the following minimum safe distances.

*Ask the power company about the voltage of power cables at the job site.

| Voltage of power cables | Minimum safe distance |
|-------------------------|-----------------------|
| 6.6 kV | 3 m |
| 33.0 kV | 4 m |
| 66.0 kV | 5 m |
| 154.0 kV | 8 m |
| 275.0 kV | 10 m |

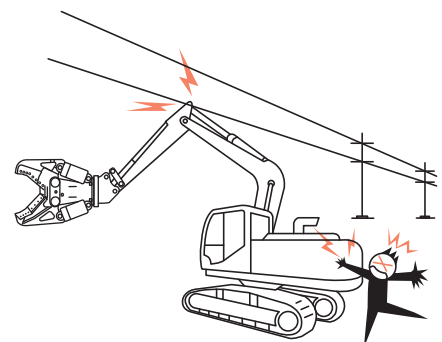

Warning

2-11 Maintain sufficient visibility

- Turn on the work lights of the hydraulic excavator in dark locations. Furthermore, brighten the area by preparing lighting equipment as necessary.

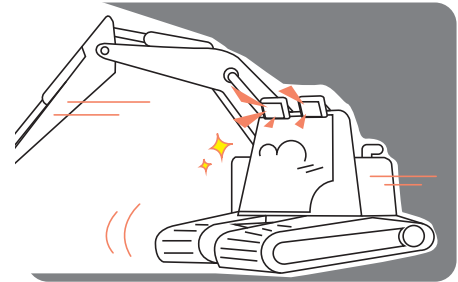

- Stop work immediately when visibility is bad due to bad weather, clouds of dust, etc.



2-12 Cautions about slopes

- If the excavator body has slipped or become unstable while travelling, immediately lower the attachment to the ground and stop travelling.

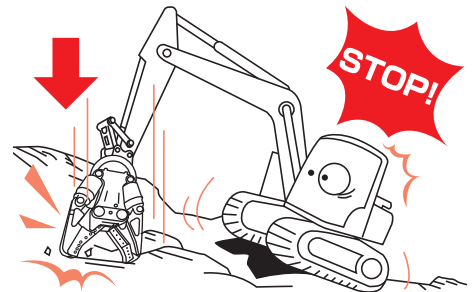

- Be careful that the hydraulic excavator does not tip over when working with heavy loads on sloping land. Furthermore, do not swivel the hydraulic excavator.



Warning

2-13 Watch for collisions

When you are working in a location in which the height is restricted, such as in a tunnel, under an overpass or power cables, or when parking in a garage, take sufficient care not to hit the attachment or working equipment (boom and stick) of hydraulic excavator.

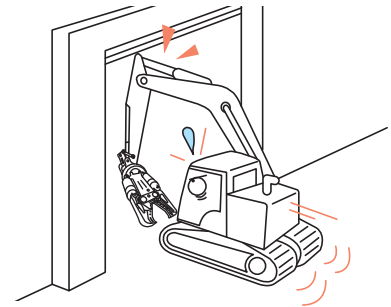

2-14 Do not perform excessive work

① Do not perform punching work

This product is a cutting and crushing attachment.
Do not use it for prying, sideswipes, or striking.

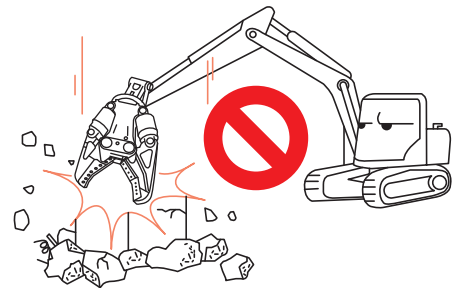

② Do not demolish concrete with the cutting blade section

Do not demolish concrete with the cutting blade section.
The cutting blade will be damaged if you use it to demolish concrete.

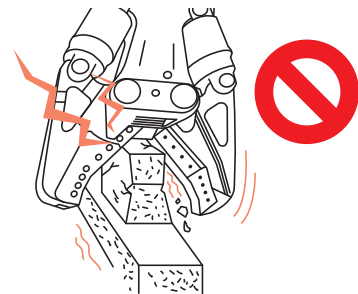

③ Do not secure the boom and stick of the hydraulic excavator

When you using the attachment, do not secure the boom and stick of the hydraulic excavator by contact with another object. This can bend the boom and stick of the hydraulic excavator or other parts.

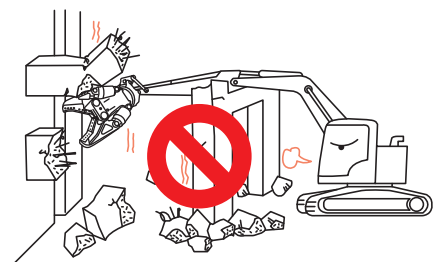

④ Do not perform leveling work

Do not level crushed materials or residual soil using the attachment. Otherwise, both the attachment and the hydraulic excavator may be damaged.

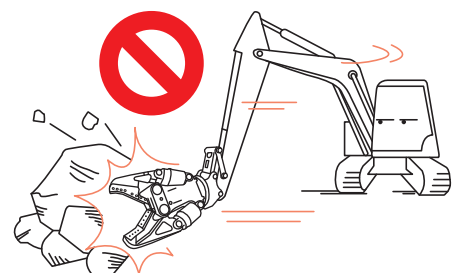

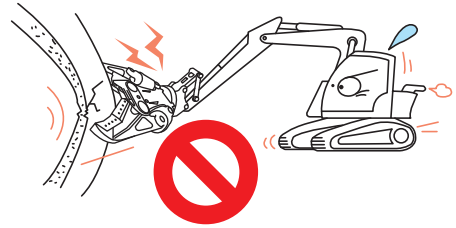

Warning
2-14 Do not perform excessive work**⑤ Do not perform operations simultaneously**

Do not operate the boom and stick of the hydraulic excavator, move the hydraulic excavator, or perform any other operations while using the attachment. An abnormal force may be applied and damage the attachment, stick and link of the hydraulic excavator, and other parts.

**⑥ Do not operate at the stroke-end**

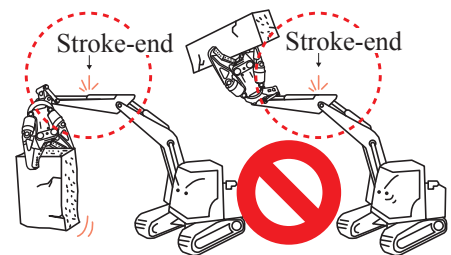
Do not use the stroke-end of the hydraulic excavator's cylinder. Do not use the attachment when the bucket cylinders of the hydraulic excavator are fully extended or retracted. It may damage the stick, link and pin or other parts of the hydraulic excavator.

**⑦ Do not jack up the hydraulic excavator using the attachment**

An unreasonable force will work on the boom and stick of the hydraulic excavator and may break both the attachment and hydraulic excavator.

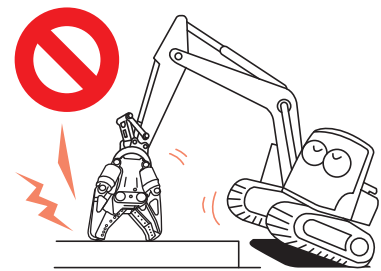
**⑧ Do not use the turning force of the hydraulic excavator to create an impact**

Excessive force will be applied to the attachment and upper components of the excavator, which may cause a damage.

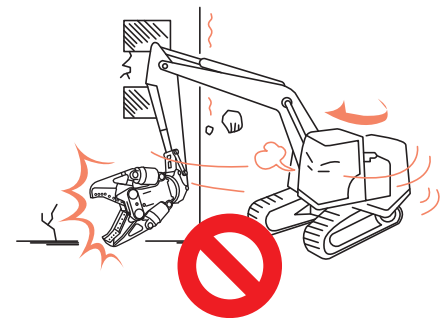
**⑨ Do not grasp items from an angle**

Excessive force will be applied to the jaw and rotating parts of the attachment, which may cause a damage.

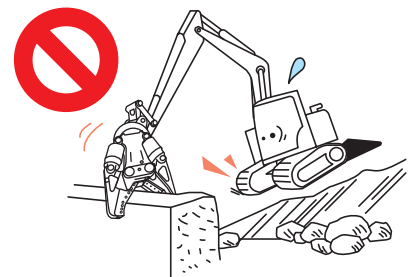



Warning
2-14 Do not perform excessive work**⑩ Do not lift materials**

Lifting objects using an attachment of a hydraulic excavator is a violation of law in Japan.

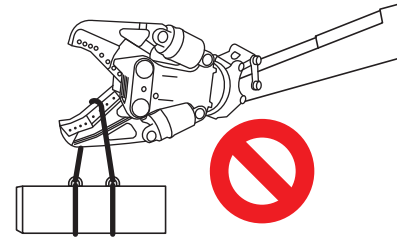
Moving objects using the hydraulic excavator is also considered crane work.

**⑪ Cutting the joint portion**

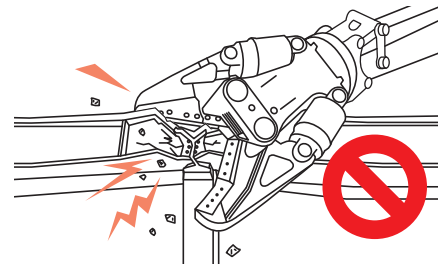
Do not cut steel joints, doubling parts, and parts fastened with bolts or rivets.

**Notice****2-15 Do not use the attachment to crush fieldstone.**

Do not use the attachment to crush granite or other fieldstone.

**2-16 Use the cutting blade to cut only rebar and steel frames**

Do not use the cutting blade to cut items other than rebar and steel frames. Crushing concrete with the cutting blade will cause abnormal wear or other damage. Do not cut steel frames that exceed the ability of the cutter.

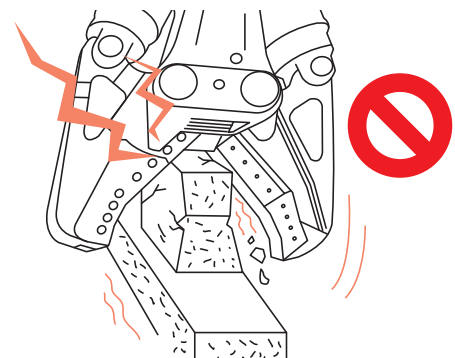

- For DX-SRC Crushing Cutter I-Beam maximum cutting ability, refer to “Specifications and Dimensions” (P.32).

3. Cautions while travelling

Warning

3 Cautions while travelling

- When the attachment is installed, the balance of the excavator body is very different from when the standard bucket is installed. Be careful the hydraulic excavator does not tip over when swiveling or when a working equipment (boom and stick) is extended.
- Before travelling, bring the attachment and working equipment (boom and stick) to the front as much as possible. Travelling while a working equipment (boom and stick) extended is very dangerous because the excavator body becomes unstable. Furthermore, keep the tip of the attachment 30 to 40 cm above the ground so that it can be lowered and stopped immediately in an emergency.
- Do not travel with your foot resting on the operation pedal of the hydraulic excavator because the attachment may move suddenly.
- While travelling, pay attention to the safety of your surroundings. Particularly when you are travelling backwards, or on a slope, make sure there are no people around, and then proceed with caution.
- Hydraulic excavators have blind spots. Before turning, make sure that no one is under the hydraulic excavator.

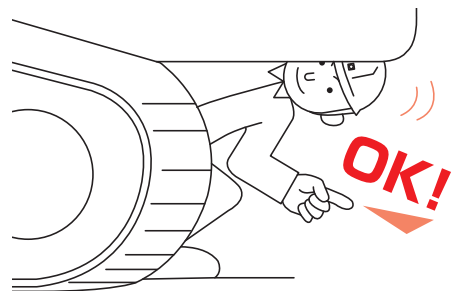
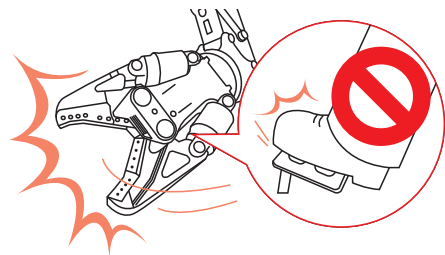
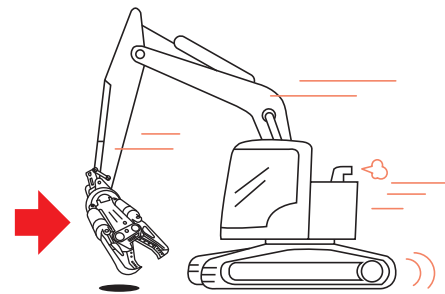
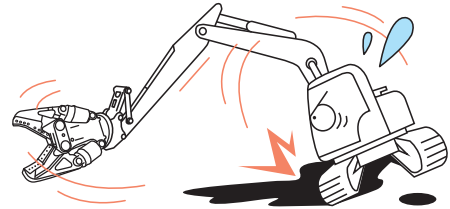

4. Cautions after operation

Warning

4-1 Cautions when leaving the driver's seat

- Before leaving the body of the excavator, bring the working equipment (boom and stick) or attachment to the front and place it on the ground reliably. Furthermore, always stop the engine of the hydraulic excavator.

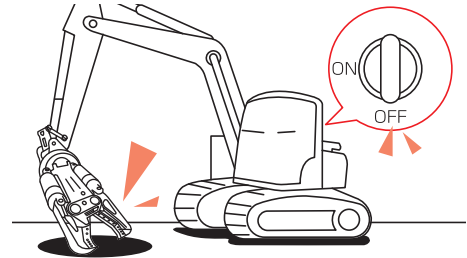

- Do not leave the driver's seat while operation.

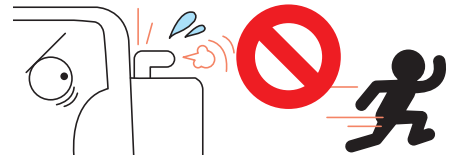

- Do not sit or ride on a working equipment (boom and stick).

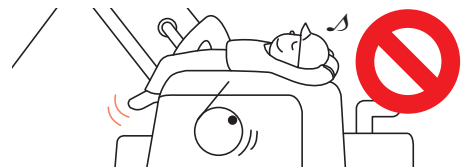

4-2 Safely store the attachment

- Depending on the storage position, there is a risk that the attachment may fall over. Choose a location with a flat solid surface, and store the attachment stably on a support stand, rectangular lumber, etc.

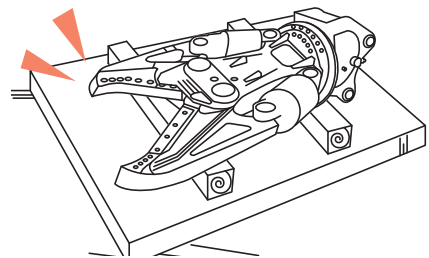

- If the attachment will be stored for a long time, choose a location that is not exposed to rain and store the attachment wrapped in a protective sheet or similar item.

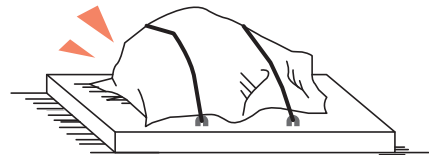

- Do not let children or third parties enter the storage area.



Warning

4-2 Safely store the attachment

- To stop the jaw of the attachment from moving, always attach the blind plug to the connection hose.

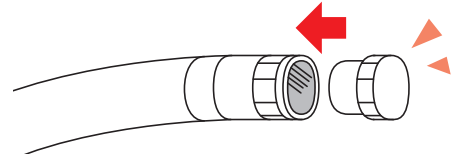

4-3 Maintenance position

- Before maintaining the attachment, always place a stand, rectangular lumber, or other similar item on a solid flat surface, and then place the attachment on it in a stable condition.

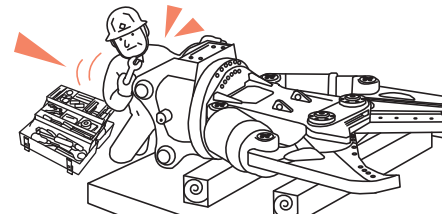

- Do not support the jaw of the attachment by the hydraulic cylinder only. This is dangerous because the jaw may fall (close) if the operation pedal is accidentally pressed, the hydraulic line is damaged, or the hydraulic piping parts are removed.

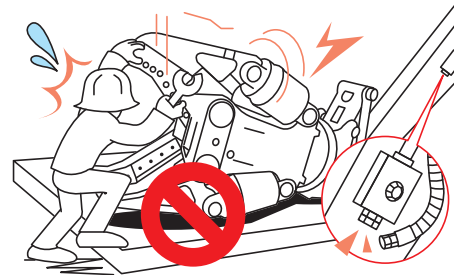

- Never work while the attachment is raised.

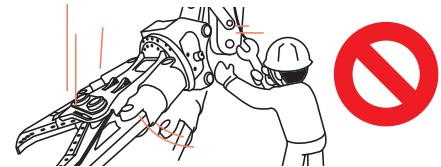

- Before maintenance, always stop the engine of the hydraulic excavator, and then switch OFF the stop valve of the hydraulic piping.

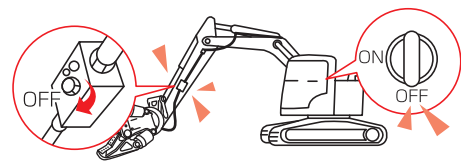

 **Warning****4-4 Managing hydraulic oil**

- When the attachment is installed, it is assumed that the hydraulic oil will deteriorate quickly because the hydraulic oil reaches higher temperatures and pressures more often than with standard bucket excavation work. Follow the inspection and maintenance rules for the hydraulic excavator and observe the exchange time for the hydraulic oil.
- Soiling, contamination, time-related deterioration, and other conditions of the hydraulic oil may cause problems for hydraulic equipment. Follow the inspection and maintenance rules for the hydraulic excavator and observe the exchange time for the filter (element) of the hydraulic circuit.

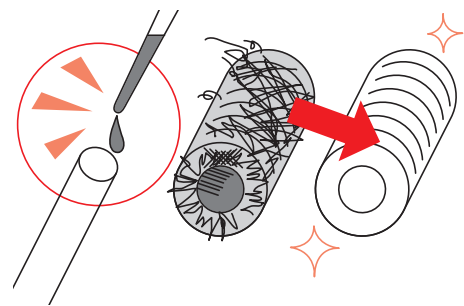

 **Warning**
4-5 Watch for high-pressure oil

- Carefully check the hydraulic lines for leaks before and after work because leaks may cause fire or other serious accidents.

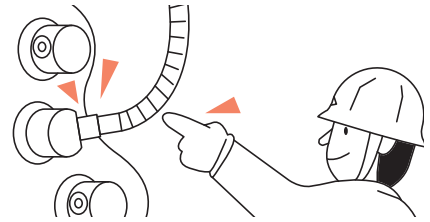

- Be aware that the hydraulic line has a constant internal pressure.

Do not supply or discharge oil or perform inspection and maintenance work before the internal pressure becomes zero. For the procedure to relieve the internal pressure, see “Releasing internal pressure of hydraulic circuit to prevent high-temperature/high-pressure oil spouting” (P.66) of the Inspection/Maintenance section.

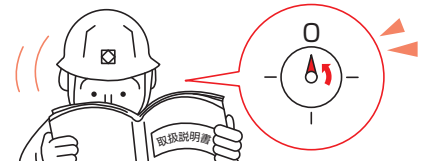

- If a leak of high-temperature/high-pressure oil from a small hole hits the skin or eye, there is a risk of blindness or serious injury. During an inspection, wear safety glasses and thick gloves and put thick paper, plywood, or a similar item on the inspection site. If you accidentally touch high-temperature/high-pressure oil, obtain medical treatment from a doctor immediately.

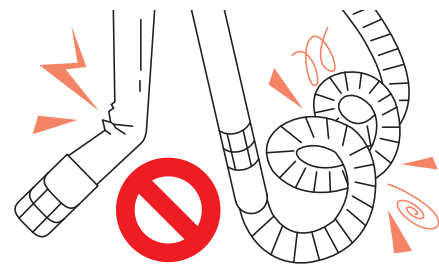

- Do not bend or strike the pipes of the hydraulic circuits of working equipment (boom and stick). Do not bend and install tubes and hoses or install damaged items.

**4-6 Watch for fire and explosions**

- Do not weld or gas cut tubes or pipes containing flammable oil.

Furthermore, do not allow heat from welding or other work near hydraulic equipment or plumbing. Before doing such work, remove the oil and clean the area.



Operation

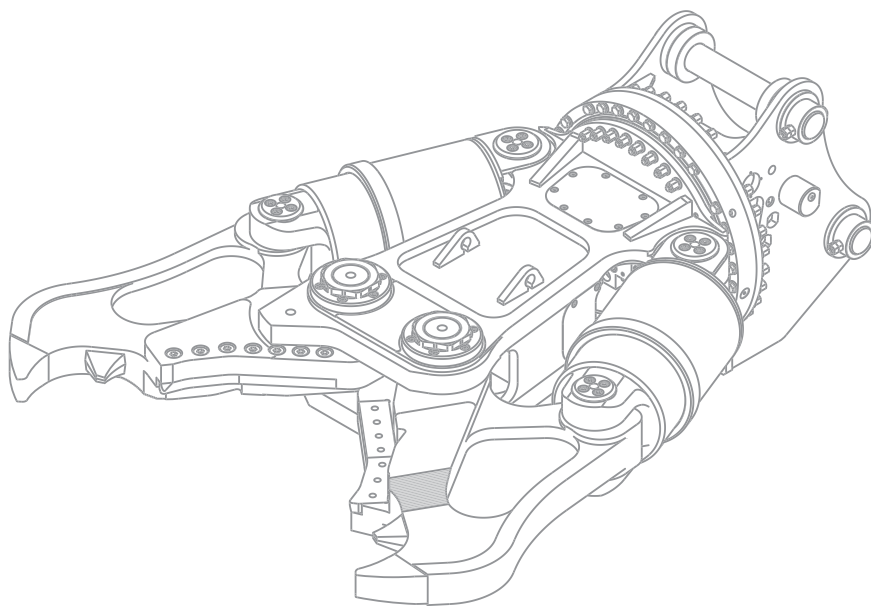

Warning

Carefully read and understand the Safety section (P.11) before reading this section.

Specifications and Dimensions

Hydraulic rotation type (S type)

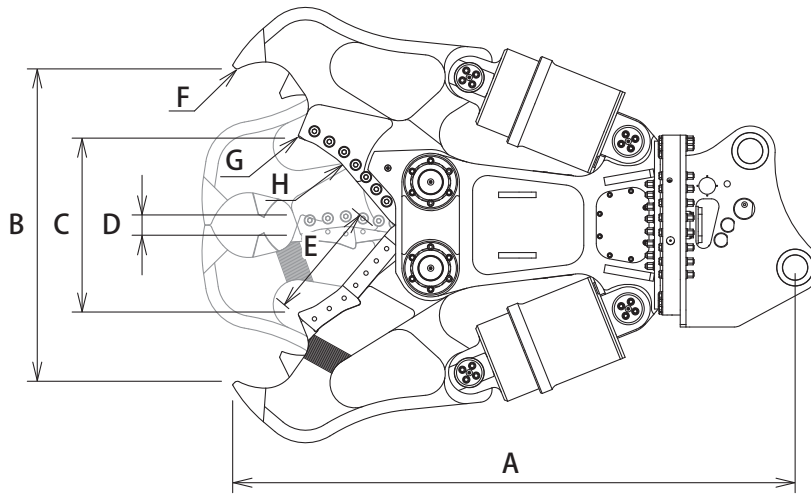

| Model name | | DX-SRC-135S | DX-SRC-212S | DX-SRC-352S |
|---------------------------------|----------------------------|-------------|-------------|-------------|
| Class of excavator | ton | 12-14 | 20-22 | 30-37 |
| Operating pressure | MPa (kgf/cm ²) | 31.4 (320) | | |
| Max. operating pressure | MPa (kgf/cm ²) | 34.3 (350) | | |
| Open/close required flow rate | L/min | 240 | 400 | 600 |
| Rotation pressure | MPa (kgf/cm ²) | 14.2 (145) | | |
| Rotation required flow rate | L/min | 40 | 50 | |
| A Length | mm | 1930 | 2250 | 2560 |
| B Max. jaw opening | mm | 1000 | 1250 | 1510 |
| C Max. blade opening | mm | 555 | 695 | 800 |
| D Min. blade opening | mm | 85 | 80 | 120 |
| E Cutting blade length | mm | 405 | 470 | 560 |
| F Crushing force at tip | kN (tf) | 680 (69) | 1220 (124) | 1460 (149) |
| G Cutting force at blade tip | kN (tf) | 978 (100) | 1760 (179) | 2160 (220) |
| H Cutting force at blade center | kN (tf) | 1500 (153) | 2680 (273) | 3470 (354) |
| Mass | kg | 1530 | 2450 | 3870 |

- Double two-way hydraulic piping is required. (However, drain piping is required when the back pressure of the rotation line exceeds 2 MPa (20 kgf/cm².)
- We recommend reinforcing the stick of a hydraulic excavator that has this product installed.
- The weights in the table are reference values. For the weight of products, refer to “Product name-plates”.
- The attachment cannot be installed on a hydraulic excavator of a different class.

DX-SRC Crushing I-Beam maximum cutting ability (Units : mm) I-Beam dimensional diagram

| Model name | I-Beam | | | | | | | |
|-------------|-----------------|-----------|----------------|----------------|-------------------|-----------|----------------|----------------|
| | Structural/wide | | | | Structural/narrow | | | |
| | Height (H) | Width (B) | Thickness (t1) | Thickness (t2) | Height (H) | Width (B) | Thickness (t1) | Thickness (t2) |
| DX-SRC-135S | 200 | 200 | 8 | 12 | 350 | 170 | 7 | 11 |
| DX-SRC-212S | 300 | 300 | 10 | 15 | 500 | 200 | 10 | 16 |
| DX-SRC-352S | 350 | 350 | 12 | 19 | 600 | 300 | 12 | 17 |

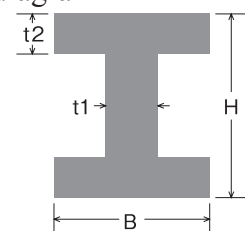

■ Automatic rotation type (A type)

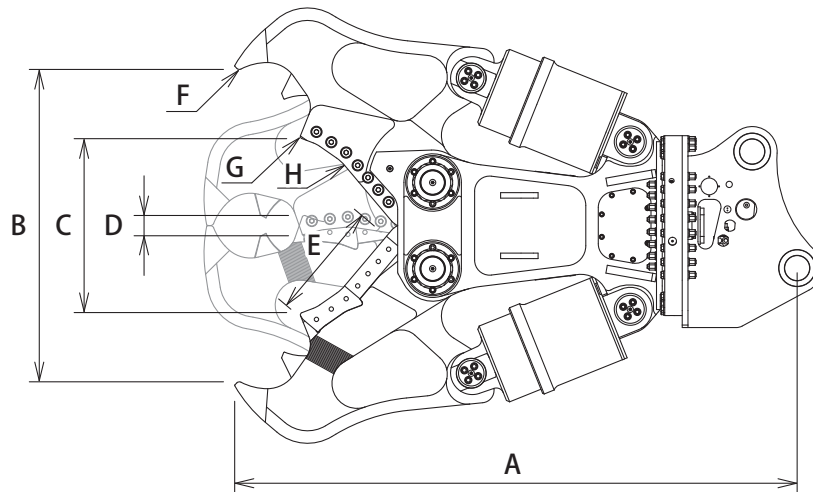

| Model name | | DX-SRC-135A | DX-SRC-212A | DX-SRC-352A |
|---------------------------------|----------------------------|-------------|-------------|-------------|
| Class of excavator | ton | 12-14 | 20-22 | 30-37 |
| Operating pressure | MPa (kgf/cm ²) | 31.4 (320) | | |
| Max. operating pressure | MPa (kgf/cm ²) | 34.3 (350) | | |
| Required flow rate | L/min | 240 | 400 | 600 |
| A Length | mm | 1930 | 2250 | 2560 |
| B Max. jaw opening | mm | 1000 | 1250 | 1510 |
| C Max. blade opening | mm | 555 | 695 | 800 |
| D Min. blade opening | mm | 85 | 80 | 120 |
| E Cutting blade length | mm | 405 | 470 | 560 |
| F Crushing force at tip | kN (tf) | 680 (69) | 1220 (124) | 1460 (149) |
| G Cutting force at blade tip | kN (tf) | 978 (100) | 1760 (179) | 2160 (220) |
| H Cutting force at blade center | kN (tf) | 1500 (153) | 2680 (273) | 3470 (354) |
| Mass | kg | 1530 | 2450 | 3870 |

- Single two-way hydraulic piping is required. (Rotation may not be possible when the operating pressure is low.)
- We recommend reinforcing the stick of a hydraulic excavator that has this product installed.
- The weights in the table are reference values. For the weight of products, refer to “Product name-plates”.
- The attachment cannot be installed on a hydraulic excavator of a different class.

DX-SRC Crushing I-Beam maximum cutting ability (Units : mm) I-Beam dimensional diagram

| Model name | I-Beam | | | | | | | |
|-------------|-----------------|-----------|----------------|----------------|-------------------|-----------|----------------|----------------|
| | Structural/wide | | | | Structural/narrow | | | |
| | Height (H) | Width (B) | Thickness (t1) | Thickness (t2) | Height (H) | Width (B) | Thickness (t1) | Thickness (t2) |
| DX-SRC-135A | 200 | 200 | 8 | 12 | 350 | 170 | 7 | 11 |
| DX-SRC-212A | 300 | 300 | 10 | 15 | 500 | 200 | 10 | 16 |
| DX-SRC-352A | 350 | 350 | 12 | 19 | 600 | 300 | 12 | 17 |

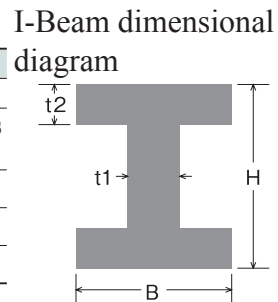

■ Automatic/hydraulic rotation type (AS type)

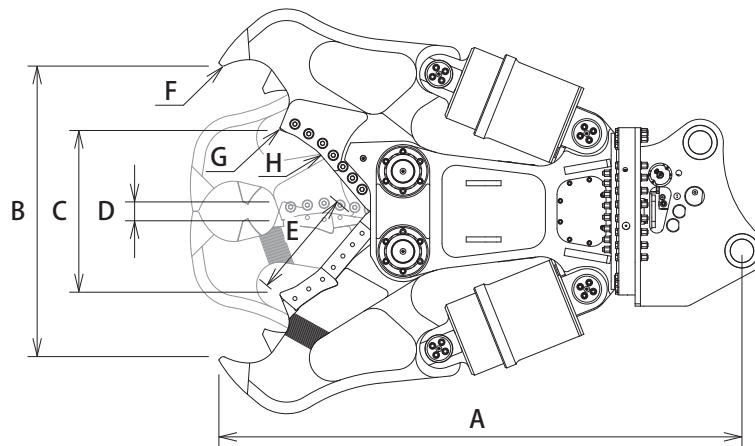

| Model name | | DX-SRC-72AS | DX-SRC-135AS | DX-SRC-212AS | DX-SRC-352AS |
|---|----------------------------|-------------|--------------|--------------|--------------|
| Class of excavator | ton | 6-8 | 12-14 | 20-22 | 30-37 |
| Operating pressure | MPa (kgf/cm ²) | 24.5 (250) | 31.4 (320) | | |
| Max. operating pressure | MPa (kgf/cm ²) | 27.4 (280) | 34.3 (350) | | |
| Required flow rate (in A mode) | MPa (kgf/cm ²) | 140 | 240 | 400 | 600 |
| Open/close required flow rate (in S mode) | L/min | 140 | 240 | 400 | 600 |
| Rotation pressure (in S mode) | L/min | 11.2 (115) | 14.2 (145) | | |
| Rotation required flow rate (in S mode) | MPa (kgf/cm ²) | 30 | 40 | 50 | |
| A Length | mm | 1670 | 1930 | 2250 | 2560 |
| B Max. jaw opening | mm | 730 | 1000 | 1250 | 1510 |
| C Max. blade opening | mm | 400 | 555 | 695 | 800 |
| D Min. blade opening | mm | 65 | 85 | 80 | 120 |
| E Cutting blade length | mm | 355 | 405 | 470 | 560 |
| F Crushing force at tip | kN (tf) | 385 (39) | 680 (69) | 1220 (124) | 1460 (149) |
| G Cutting force at blade tip | kN (tf) | 573 (58) | 978 (100) | 1760 (179) | 2160 (220) |
| H Cutting force at blade center | kN (tf) | 920 (94) | 1500 (153) | 2680 (273) | 3470 (354) |
| Mass | kg | 860 | 1540 | 2470 | 3880 |

- In the case of use in A mode, single two-way hydraulic piping is required. (Rotation may not be possible when the operating pressure is low.)
- In the case of use in S mode, double two-way hydraulic piping are required. (However, drain piping is required when the back pressure of the rotation line exceeds 2 MPa (20 kgf/cm².)
- We recommend reinforcing the stick of a hydraulic excavator that has this product installed.
- The weights in the table are reference values. For the weight of products, refer to “Product nameplates”.
- The attachment cannot be installed on a hydraulic excavator of a different class.

DX-SRC Crushing I-Beam maximum cutting ability (Units : mm) I-Beam dimensional diagram

| Model name | I-Beam | | | | | | | |
|--------------|-----------------|-----------|----------------|----------------|-------------------|-----------|----------------|----------------|
| | Structural/wide | | | | Structural/narrow | | | |
| | Height (H) | Width (B) | Thickness (t1) | Thickness (t2) | Height (H) | Width (B) | Thickness (t1) | Thickness (t2) |
| DX-SRC-72AS | 150 | 150 | 7 | 10 | 250 | 125 | 6 | 9 |
| DX-SRC-135AS | 200 | 200 | 8 | 12 | 350 | 170 | 7 | 11 |
| DX-SRC-212AS | 300 | 300 | 10 | 15 | 500 | 200 | 10 | 16 |
| DX-SRC-352AS | 350 | 350 | 12 | 19 | 600 | 300 | 12 | 17 |

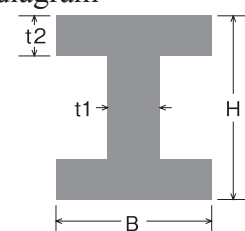

Component names

Hydraulic rotation type (S type)

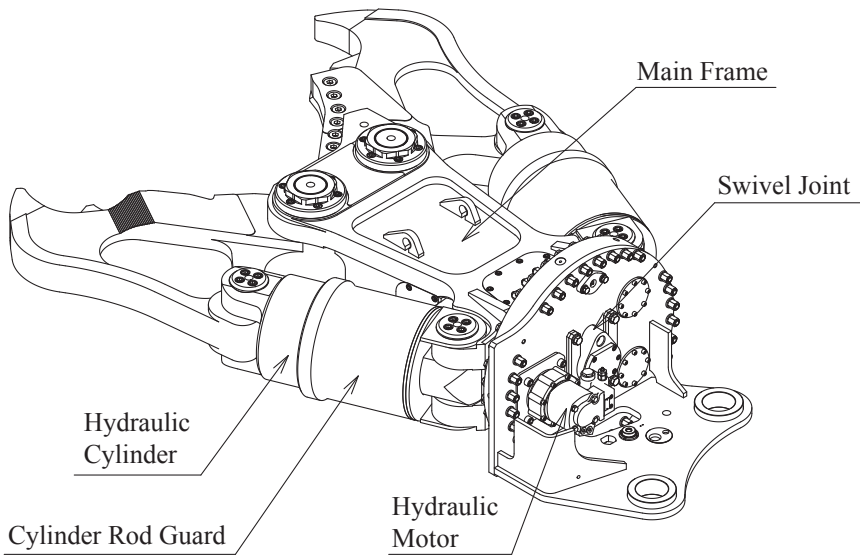
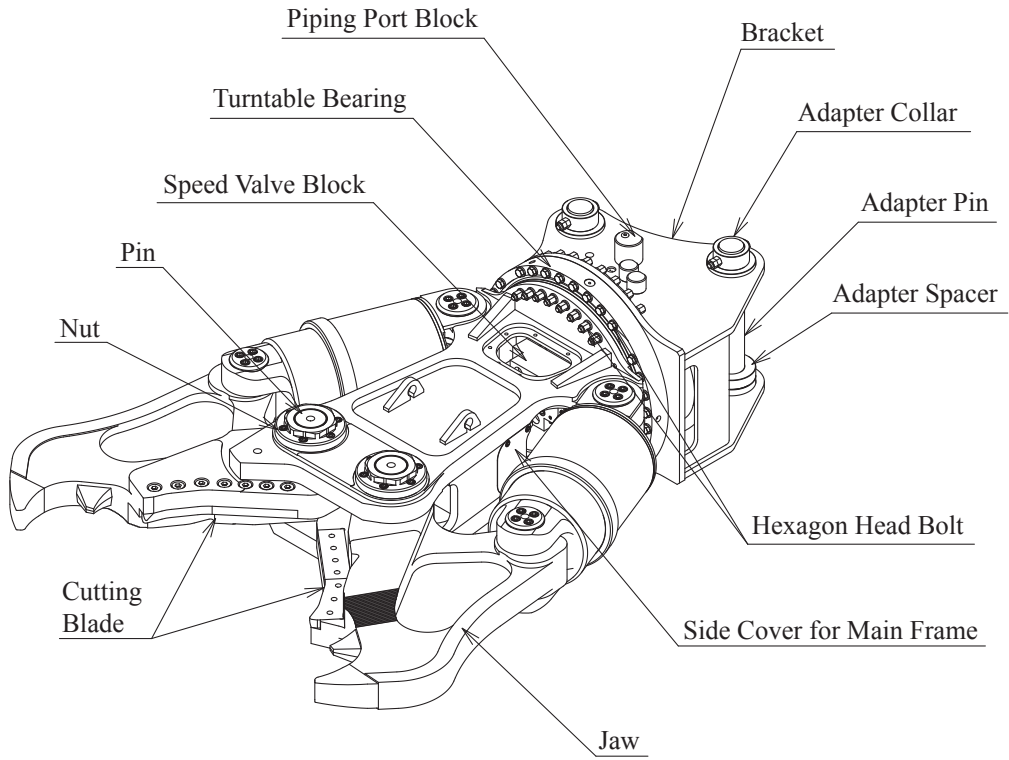

■ Automatic rotation type (A type)

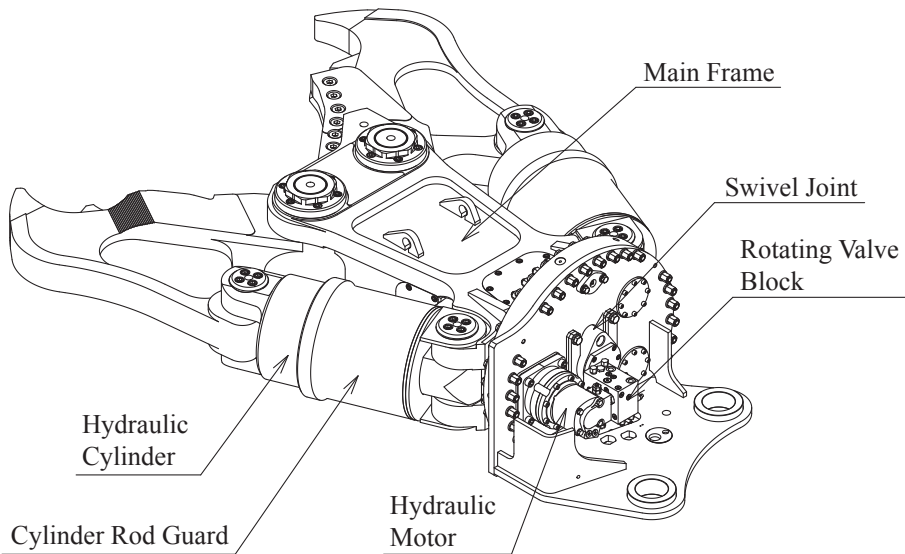
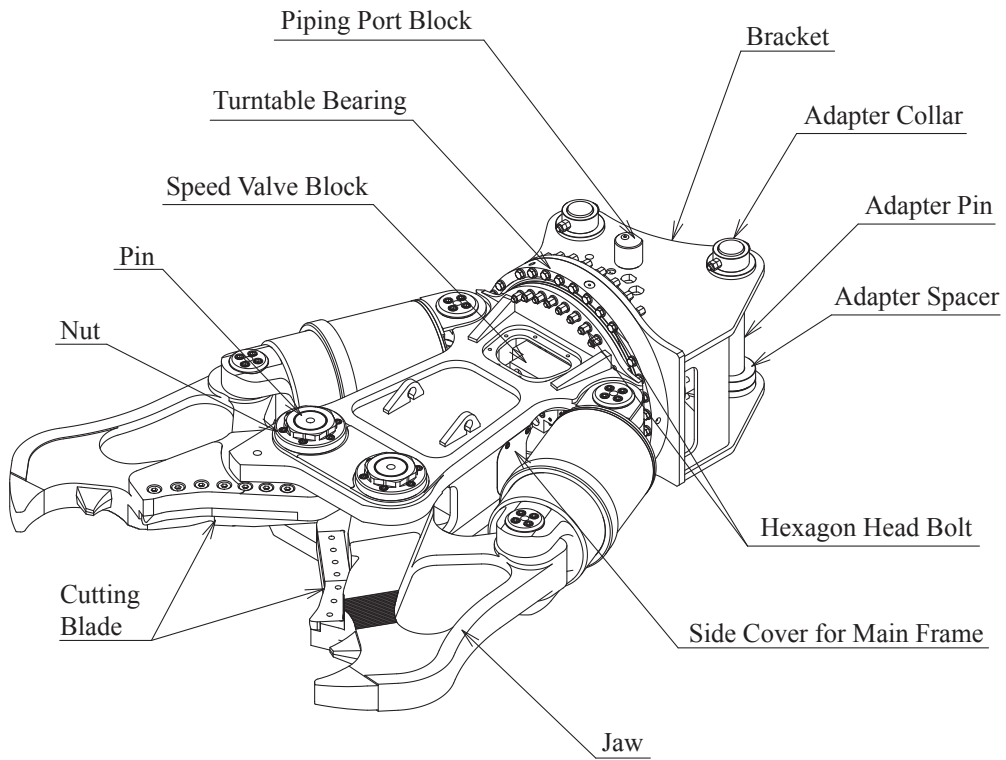

■ Automatic/hydraulic rotation type (AS type)

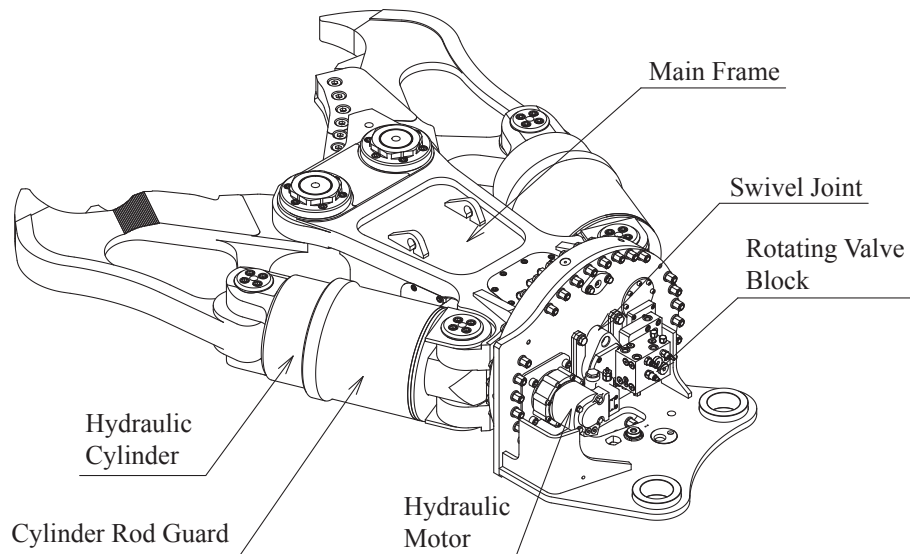
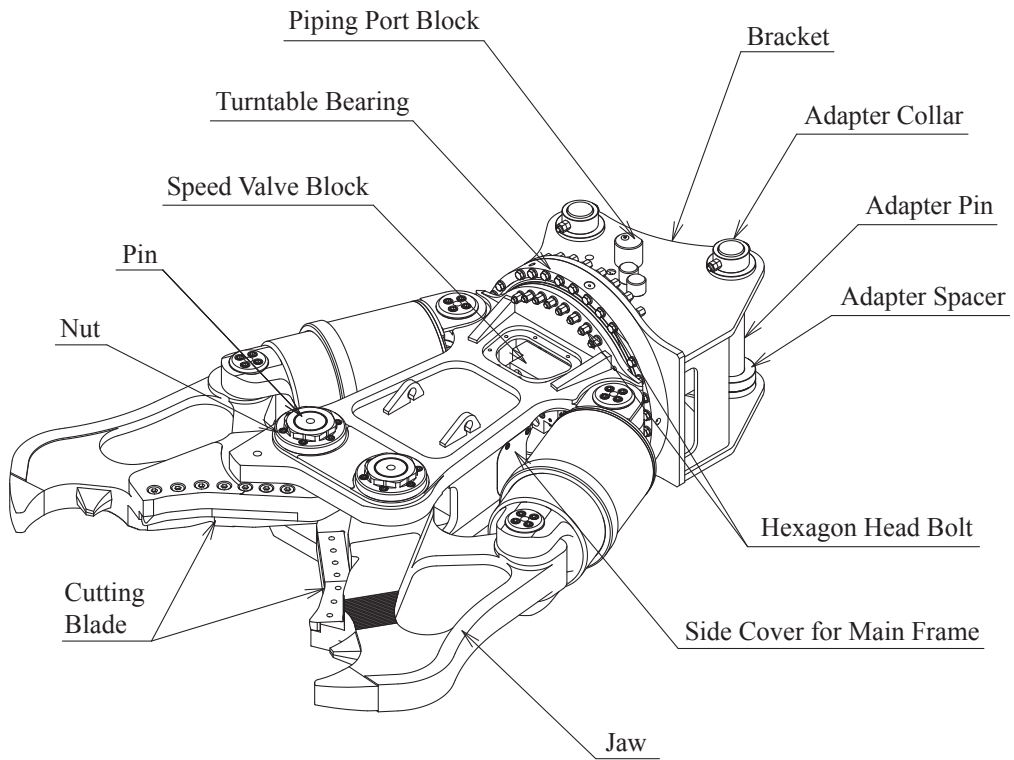

Inspections and preparation before operation

To ensure operation safety and prevent trouble with attachments and hydraulic excavators, always perform the following inspections and preparation before starting operation.

■ Inspections

- Check amount and soiling of the hydraulic oil of the hydraulic excavator.
 - If the amount is low, supply the same hydraulic oil up to the prescribed amount.
 - If contamination, dirt and deterioration are progressing, replace the full amount with the same hydraulic oil. Otherwise, contaminated or deteriorated hydraulic oil may damage the hydraulic components of product.

Notice

When you check the amount of hydraulic oil, use the inspection method listed in the manual of the hydraulic excavator.

- Inspect all the bolts and nuts of attachment parts and piping parts for looseness.
Tighten any loose sections to the suitable tightening torque (P.86 "Standard torque table") Operating attachment while some of bolts and nuts loosened, it may lead to a fatal accident.
- Inspect the attachment parts and piping parts for oil leaks.
If there is a large leak, investigate the cause and carry out countermeasures.
- Check for wear of the cutting blade surface, wear and cracks of the jaw, and inspect that the teeth are not too worn for the operation.
Have worn items hardfaced, repaired or replaced, because not only do they reduce work efficiency, but also cause damage to the attachment (P.69 "Adjusting the gap of the jaw of the attachment" and P.75 "Repair welding").
- Make sure that the stop valves on both sides of the stick of the hydraulic excavator are fully open.
- Make sure that all covers of the attachment are installed. Do not use the attachment if the covers are off.
- After the above-mentioned inspections, check the movement of attachment and make sure there are no malfunctions or unusual noises.

■ Preparation

- Due to transport conditions, the attachment has not been filled with grease. Always fill the attachment with grease before installation (P.53 "Greasing").
- Inject grease to the grease injection points at least twice a day (every four hours), including at the start of work. (About five times with a grease gun.)
A lack of grease leads to seizures, wear, damage, and other problems of parts such as the pin and bushing. Increase the number of grease applications if the lubrication locations come into contact with water during work.

- The hydraulic excavator should be warm up in cold regions or in the winter.
Set the rotation of the engine to half throttle. With the boom fully raised, relieve the hydraulic oil continuously for 10 to 15 seconds, and then wait 5 to 10 seconds. Repeat this operation for 5 to 10 minutes.

Usage temperature range of hydraulic oil: 40 through 80°C (maximum)

Switching between automatic rotation and hydraulic rotation mode (AS type)

For AS type models, it is possible to switch between automatic rotation mode (A mode) and hydraulic rotation mode (S mode) by opening and closing the stop valve (A/S switching valve) located on the side of the bracket.

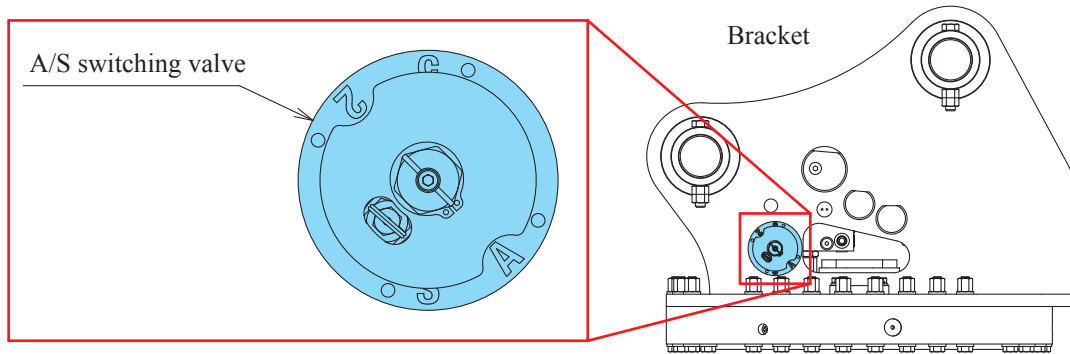

Turn the A/S switching valve to the indicated position for the mode to be used.

● **Automatic rotation mode (A mode):**

● **Hydraulic rotation mode (S mode):**

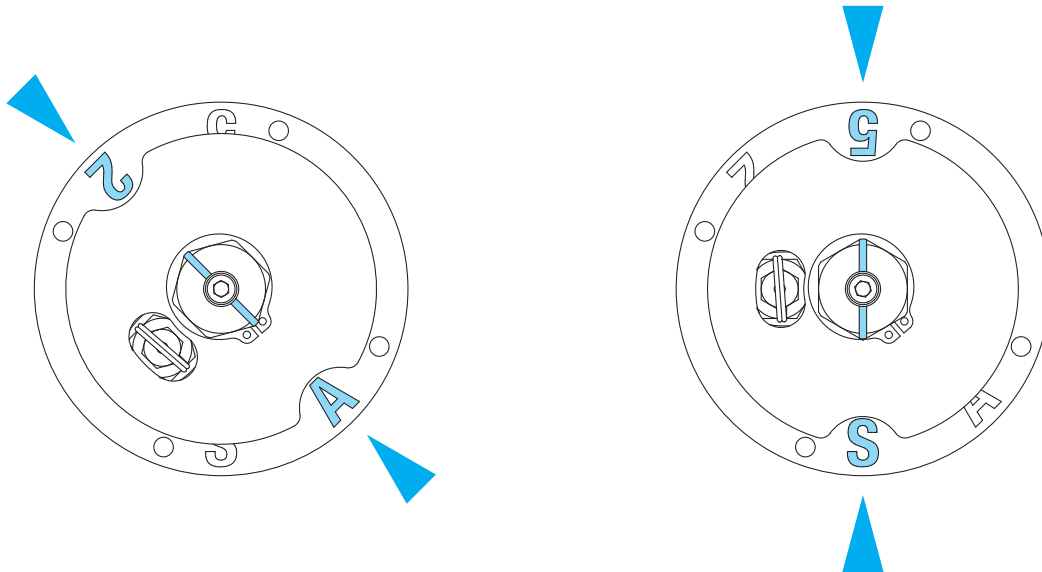

Switching between A/S modes

Notice

Before switching between A/S modes, stop the engine of the hydraulic excavator, then release the internal pressure inside the hydraulic circuit. Do not switch when there is residual pressure, as it may damage the attachment. For the procedure to relieve the internal pressure, see "Releasing internal pressure of hydraulic circuit to prevent high-temperature/high-pressure oil spouting" (P.66) of the Inspection and Maintenance section.

1 With the lock pin pulled (released), turn the A/S switching valve.

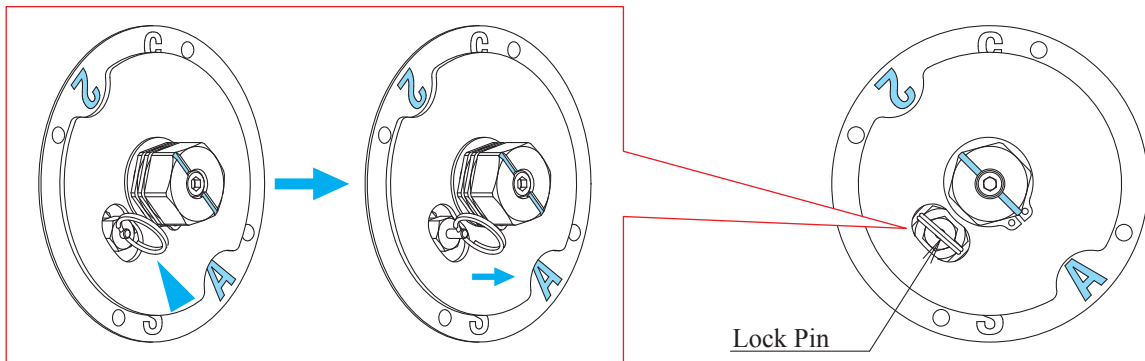

- Switching from automatic rotation mode (A mode) to hydraulic rotation mode (S mode)

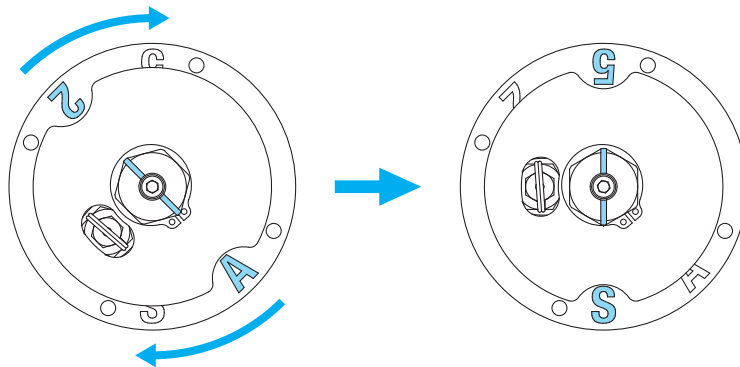

- Switching from hydraulic rotation mode (S mode) to automatic rotation mode (A mode)

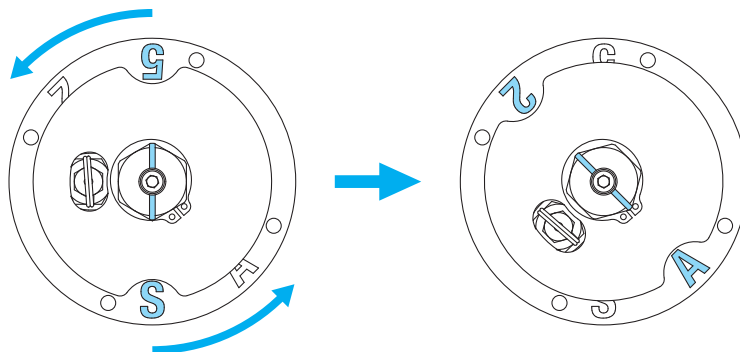

⚠ Caution

- The lock pin automatically returns to the retracted (locked) position due to the recoil of the built-in spring as letting go of the hand. Make sure to pull and release the lock pin before turning the A/S switching valve. Forcibly turning the A/S switching valve with the lock pin retracted (locked) may break or damage the attachment.

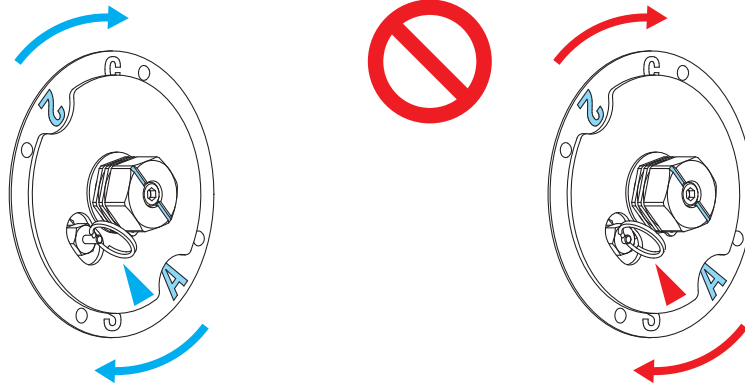

- The lock pin cannot be pulled away. Forcibly pulling away the lock pin may break or damage the attachment.
- Always turn the A/S switching valve in the indicated direction. Turning the valve in the opposite direction may damage the attachment.
 - The direction to switch from automatic rotation mode (A mode) to hydraulic rotation mode (S mode)

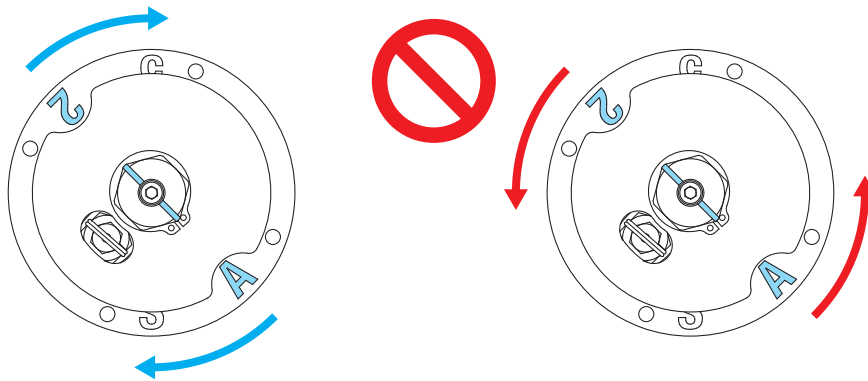

- The direction to switch from hydraulic rotation mode (S mode) to automatic rotation mode (A mode)

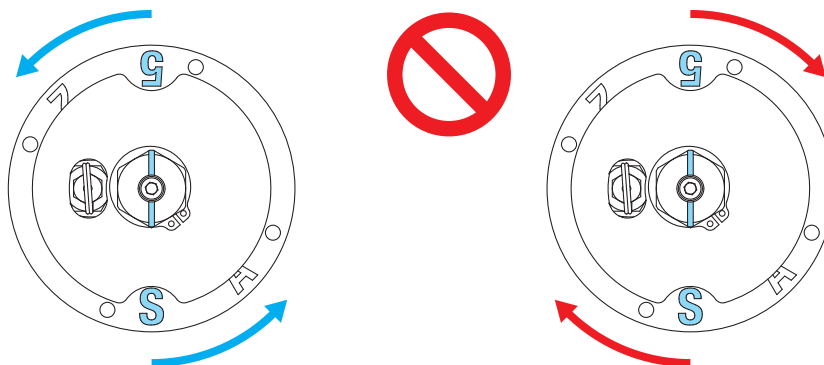

- 2 Let go of the hand and return the lock pin to the retracted (locked) position.
The procedure to switch between A/S modes is complete.

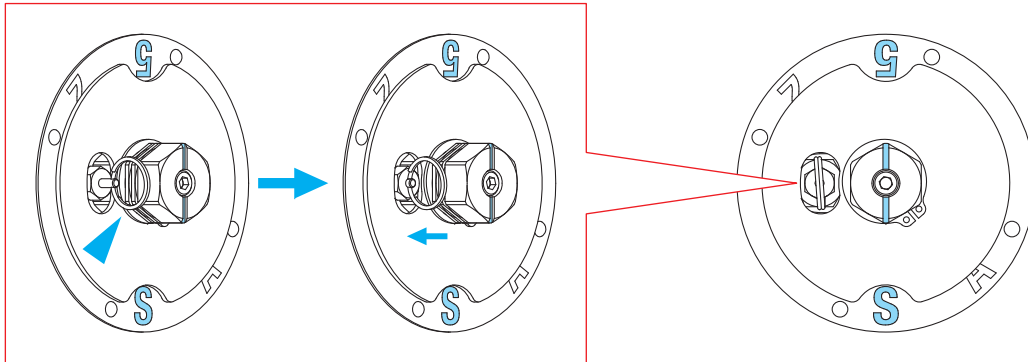

! Caution

- Do not use with the A/S switching valve in the middle position.
- Make sure that the lock pin is completely in the retracted (locked) position.

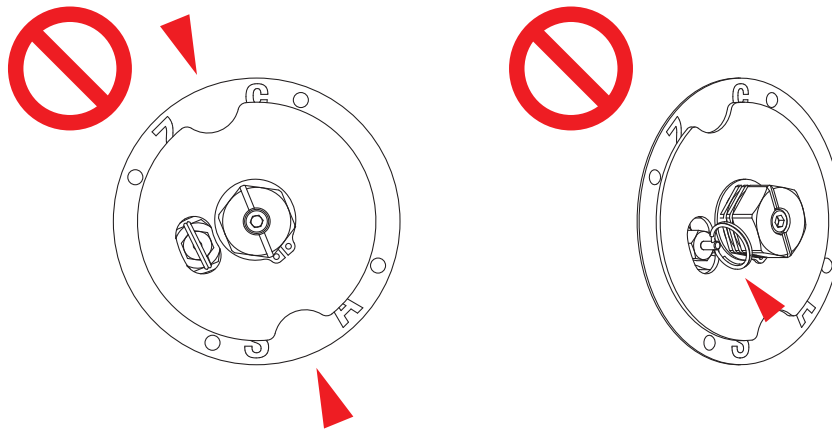

Operation control

Warning

Depending on the specifications of the hydraulic excavator, the attachment operation method and movement direction may differ from the following description. Before operation, always check the operation pattern in a safe location.

For details, see the manual of the hydraulic excavator to be used.

Notice

Before stopping the engine of a hydraulic excavator, set the engine rotation to a low idle state and operate it without load for about five minutes. Suddenly stopping the engine when its rotation is in a high idle state or the attachment is under load may shorten the life of engine parts and attachments. Do not suddenly stop the engine except in an emergency.

For details, see the instruction manual of the hydraulic excavator to be used.

■ Hydraulic rotation type (S type) and automatic/ hydraulic rotation type (AS type: S mode)

Operate the jaw by manipulating the operation pedals installed in the cab of the hydraulic excavator that follow to the hydraulic control system.

● Opening and closing the jaw

Attachment pedals

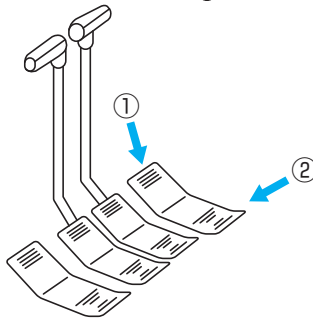

Open and close the jaw.

- ① Close: step on the toe-end of the pedal.
- ② Open: step on the heel of the pedal.

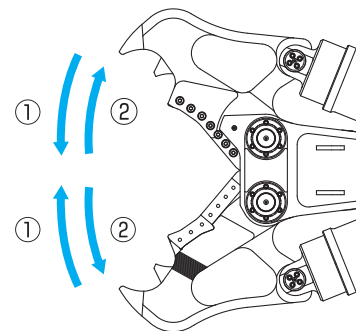

● Rotation of the jaw

Attachment pedals

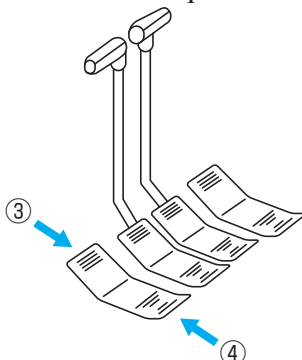

Rotate the jaw.

- ③ Rotate right (clockwise): step on the toe-end of the pedal.
- ④ Rotate left (counterclockwise): step on the heel of the pedal.

The rotation direction is the direction when viewed from the driver's seat.

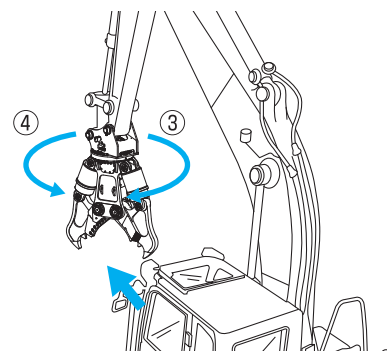

■ Automatic rotation type (A type) and automatic/hydraulic rotation type (AS type: A mode)

About Automatic Rotation Type

When you use the automatic rotation type, you can crush, cut, and rotationally position by using right-pedal operations only. If the jaw is opened completely, it switches to automatic and rotates in one direction. If you release the pedal to neutral position, the rotation stops so you can perform crushing and cutting work at the desired angle.

1 Step on heel of the right pedal to open the jaw.

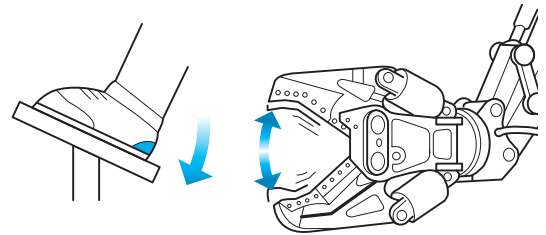

2 With the jaw completely open, continue to step on the heel to start rotation.

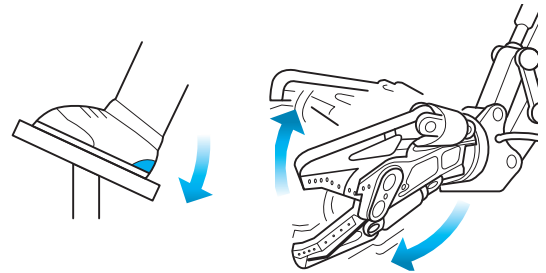

3 Return the pedal to neutral at the desired crushing/cutting position to stop rotation.

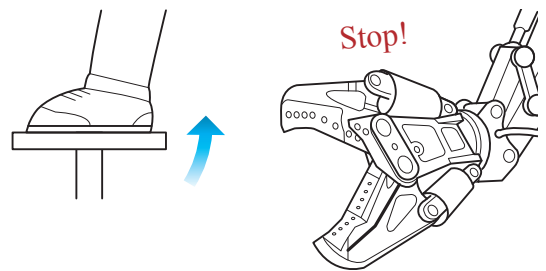

4 Press down on the toe-end of the right pedal to crush or cut.

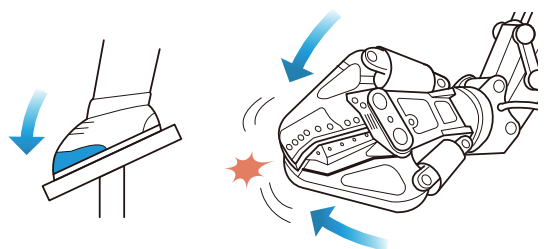

- **Contact rotation**

**Caution**

- **Automatic rotation type (A type)**

Rotation by contact rotation is also possible (both left and right). Perform contact rotation so that the tips of the jaw are placed gently against the target.

- **Automatic/hydraulic rotation type (AS type: A mode)**

Do not rotate by using contact rotation. Otherwise, the attachment may be damaged.

Installing the attachment

Warning

- Installation and removal of the attachment has a risk of the attachment falling down, being contacted, or falling over. Work in a wide flat area under stable conditions.
- When you remove the attachment, always release the residual pressure of the hydraulic piping before removing the hydraulic hose. If there is residual pressure in the circuit, high-temperature oil may shoot out, which is very dangerous. For the procedure to relieve the internal pressure, see "Releasing internal pressure of hydraulic circuit to prevent high-temperature/high-pressure oil spouting" (P.66) of the Inspection/Maintenance section.

Caution

- When attaching and detaching hoses, make sure that there is no adhesion or mixing of dirt, mud, or other foreign bodies in the piping, couplers, and hydraulic hoses. Remove all oil stains in the piping. Otherwise, the attachment and the hydraulic equipment of the hydraulic excavator may be damaged.
- Install the attachment in the correct orientation on the hydraulic excavator. If it is not installed correctly, the attachment and the stick of the hydraulic excavator may contact and be damaged.
- When you install the attachment on the hydraulic excavator, always check the following items. If these checks are not performed, the machinery may not run normally. Furthermore, an accident may result.
 - If the piping of the hydraulic excavator is a manual switching style shared with the hydraulic breaker, switch the selector valve to the crusher circuit.
 - If the piping of the hydraulic excavator is an automatic switching type, use the operation panel or switch to switch to the attachment mode before use.
 - If an actuator is installed on the piping for the hydraulic breaker, always close the safety lock valve. (This is not necessary in the case of attachment-mode automatic-switching piping.) Be sure to set all stop valves on the piping connected to the attachment to ON (fully open) before use.

Notice

- The adapter pin and adapter spacer change depending on the stick width and pin diameter of the attachment model. If you attach to a new model with a different stick width or pin diameter, an adapter pin and adapter spacer suitable for this model are necessary.
- Be sure to open any stop valves on the hydraulic line connected to the attachment after installation. If the pressure increases while one side is closed or partially open, hydraulic equipment may be damaged.
- Due to transport conditions, grease has not been filled. Always apply grease when installing (P.53 "Greasing").

- 1** Choose a location with a flat solid surface, and place the attachment stably on a support stand, rectangular lumber, etc. Install adapter spacers (4) on the inside of the bracket.

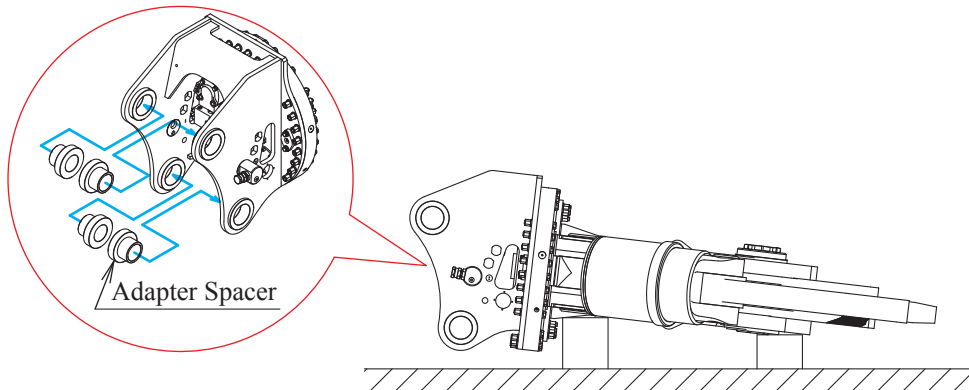

Notice

- When the automatic/hydraulic rotation type (AS type) is attached, make sure that the stop valve (A/S switching valve) is switched to the mode to be used.

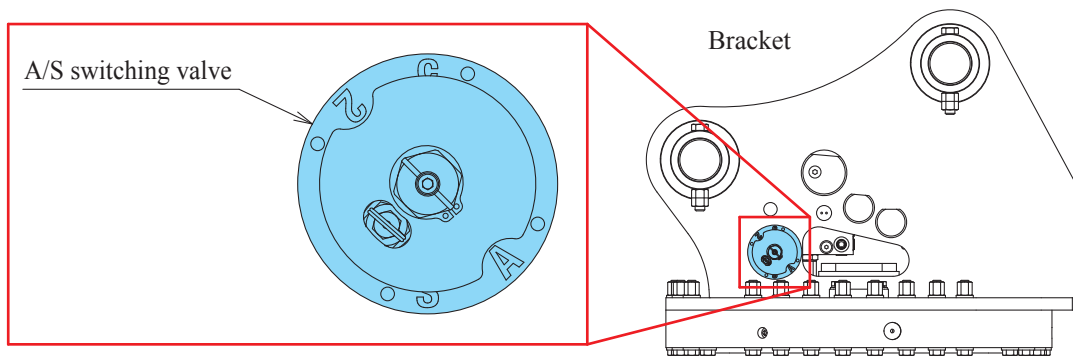

- For switching of automatic rotation mode (A mode) and hydraulic rotation mode (S mode), see "Switching between automatic rotation and hydraulic rotation mode (AS type)" (P.39) in the Operation section.

- 2 Align the pin holes on the tip of the stick of the hydraulic excavator with the installation holes of the attachment (a). Use the adapter pins and pin retainer collars, bolts, and nuts for the attachment to attach it to the hydraulic excavator.

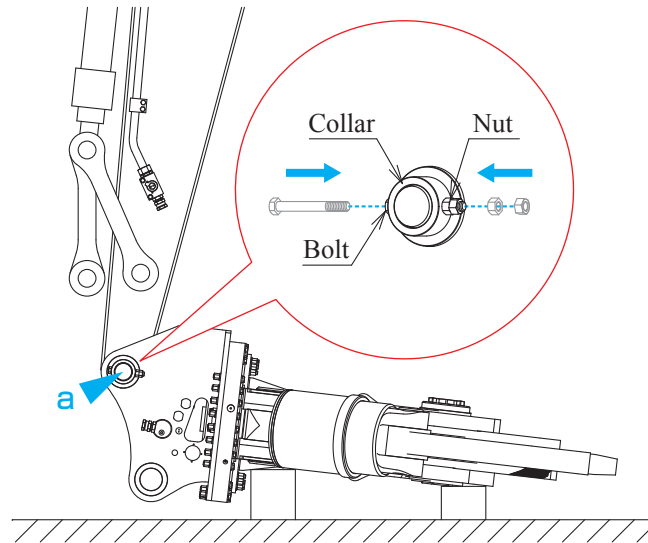

Notice

- Tighten the double nut attached to the pin retainer bolt correctly.

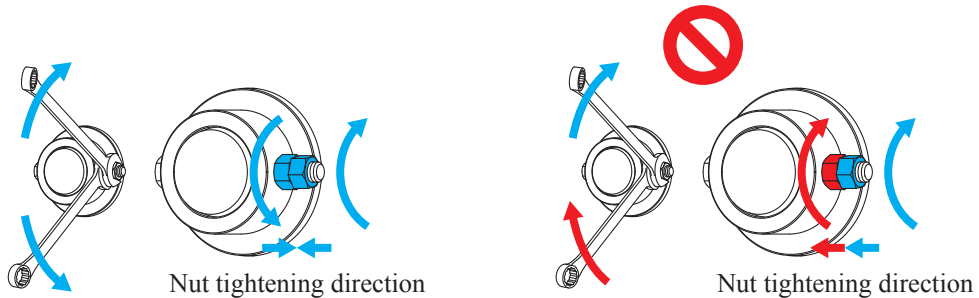

- To prevent installation mistakes, an “ARM” plate is attached to the bracket of the attachment.

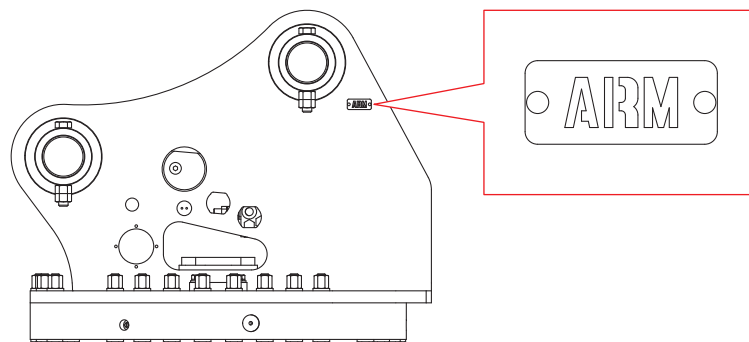

- 3** Align the pin holes on the bucket link of the hydraulic excavator with the installation holes of the attachment (**b**). Use the adapter pins and pin retainer collars, bolts, and nuts for the attachment to attach it to the hydraulic excavator.

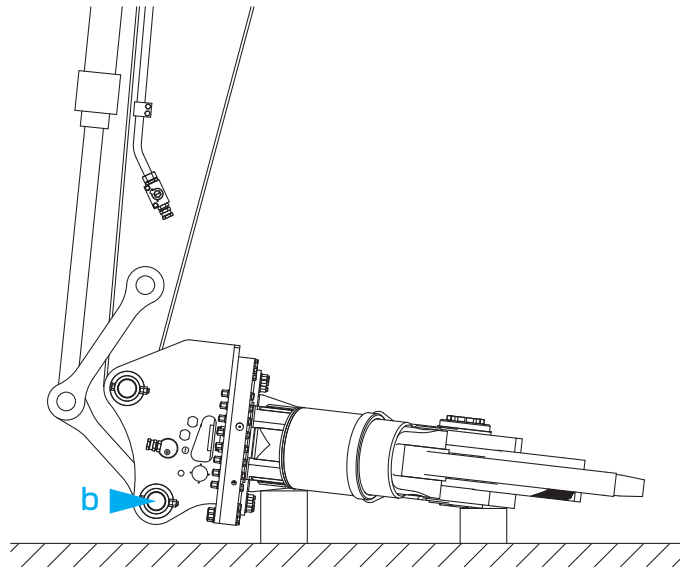

- 4** Stop the engine of the hydraulic excavator, and then release the internal pressure inside the hydraulic circuit.

For the procedure to relieve the internal pressure, see "Releasing internal pressure of hydraulic circuit to prevent high-temperature/high-pressure oil spouting" (P.66) of the Inspection/Maintenance section.

- 5 After making sure that the hydraulic oil has cooled, remove the caps of the piping port block of the attachment and the stop valve of the hydraulic excavator.

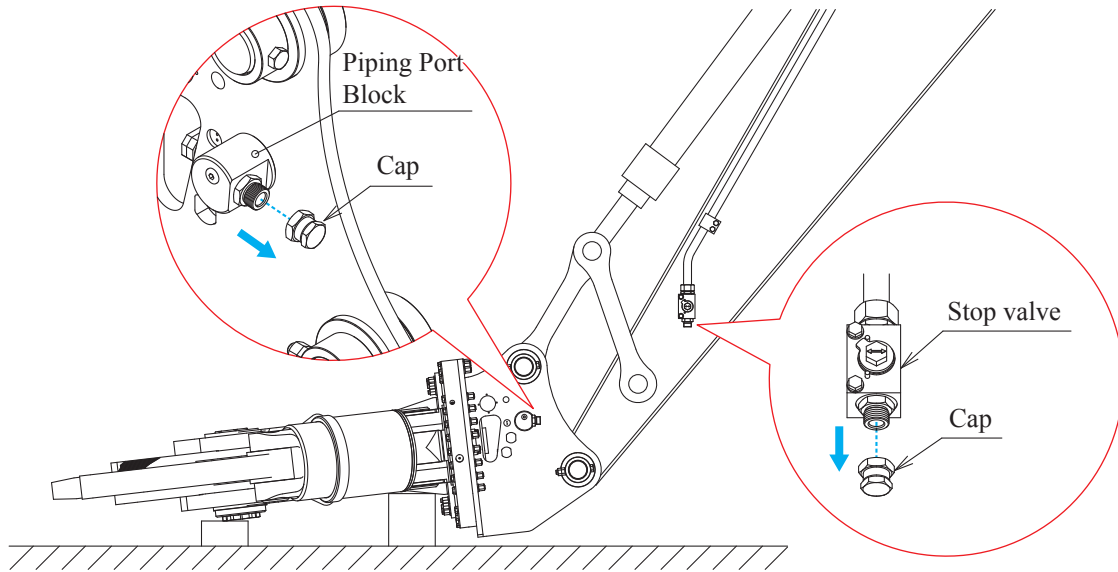

- 6 Remove the hose plugs from both ends of the connection hydraulic hose, and then connect the attachment and hydraulic excavator while not bending the hydraulic hose.

When connecting the hydraulic hose, make sure that no dirt, mud, or other foreign body gets in the hydraulic hose.

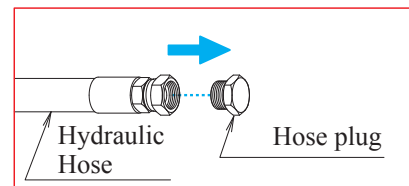

- A type
- AS type (A mode)

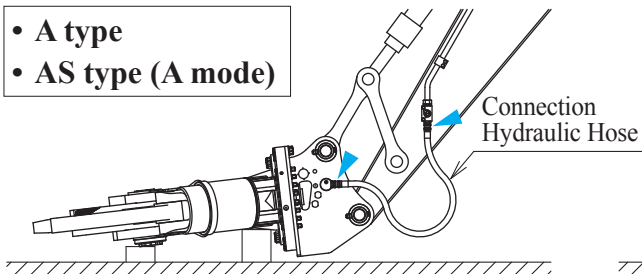

- S type
- AS type (S mode)

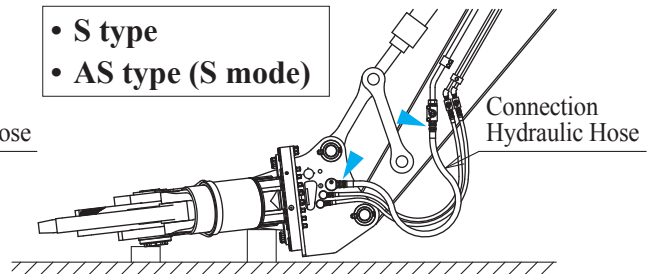

Notice

- **Automatic rotation type (A type), automatic/hydraulic rotation type (AS type: A mode):** A hydraulic excavator upon which the back pressure during rotation (hose connection part of the return side of the attachment) exceeds 2 MPa (20 kgf/cm²) cannot be used.
- **Hydraulic rotation type (S type), automatic/hydraulic rotation type (AS type: S mode):** When the back pressure during rotation (hose connection part of the return side of the attachment) exceeds 2 MPa (20 kgf/cm²), a drain line must be connected.
 - Always check the piping pattern with the hydraulic excavator manufacturer and connect the connection hydraulic hoses to the prescribed locations on the attachment and hydraulic excavator correctly.

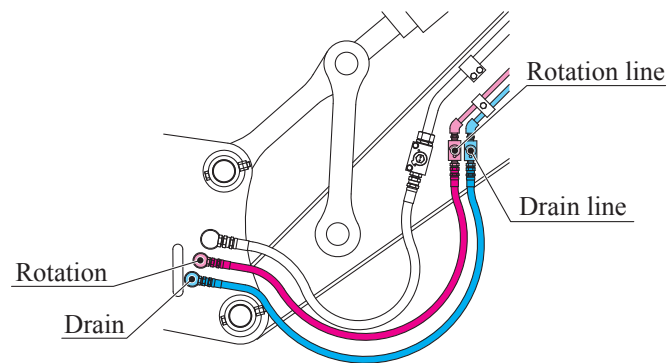

- **Incorrect connection of the drain hydraulic hose may damage the hydraulic motor inside the attachment in particular.**

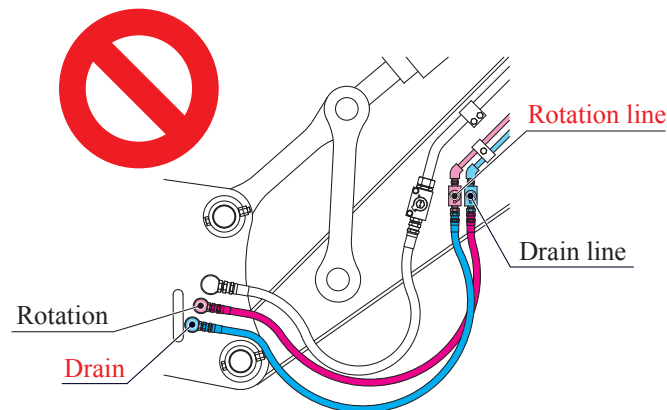

7 Due to transport conditions, the attachment has not been filled with grease. Always supply grease (P.53).

8 Set the orientation of the arrows of the stop valve of the hydraulic excavator as shown in the illustration to set the valve to ON (fully open).

The stop valve shape depends on the hydraulic excavator. For details, see the manual of the hydraulic excavator to be used.

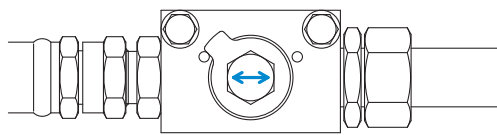

Stop valve fully open

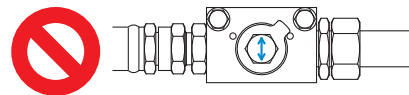

Stop valve fully closed

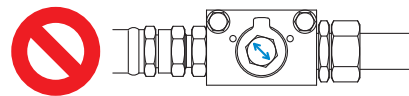

Stop valve half open

9 Start the engine of the hydraulic excavator, carefully check the operation pattern of the attachment in a safe location, and then start warm-up operations (P.58).

Always start warm-up operations to release the air in the hydraulic circuit and spread the grease inside the grease section.

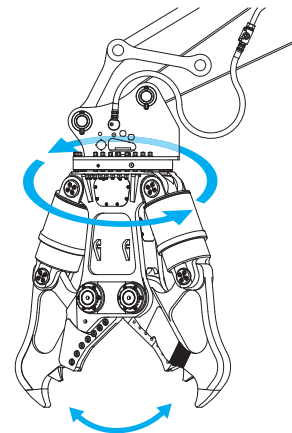

10 After warm-up operations, stop the engine of the hydraulic excavator for five minutes or more to release the air bubbles in the hydraulic oil inside the hydraulic excavator tank.

11 Check the hydraulic oil amount of the hydraulic excavator and add hydraulic oil if necessary. Take care not to overfill the hydraulic oil. The amount of hydraulic oil in the hydraulic excavator tank depends on the closing state of the jaw of the attachment and the position of the hydraulic excavator.

12 The installation procedure is complete.

Greasing



Caution

While greasing, open the jaw of the attachment and rotate it several times so that the grease spreads sufficiently.

Notice

In particular, carefully grease the attachment after it has been cleaned or become wet.

- 1 Place the attachment on the ground, and then stop the engine.
- 2 Clean the grease nipples of the lubrication points, and then use a grease gun to add grease.
- 3 You can check whether grease has been filled sufficiently by whether old grease has been pushed out from the pin, edges, matching surfaces, dust seal section, etc.
- 4 After greasing, use a cloth or similar item to wipe away the pushed-out old grease.

■ Lubrication points

Apply grease to the locations numbered in the diagram.

● Hydraulic rotation type (S type)

- DX-SRC-135S

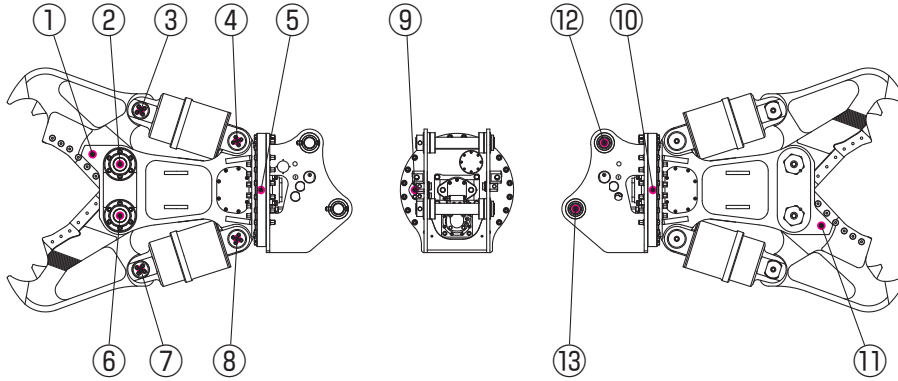

* The presence of ⑫ and ⑬ depends on the installation model.

- DX-SRC-212S

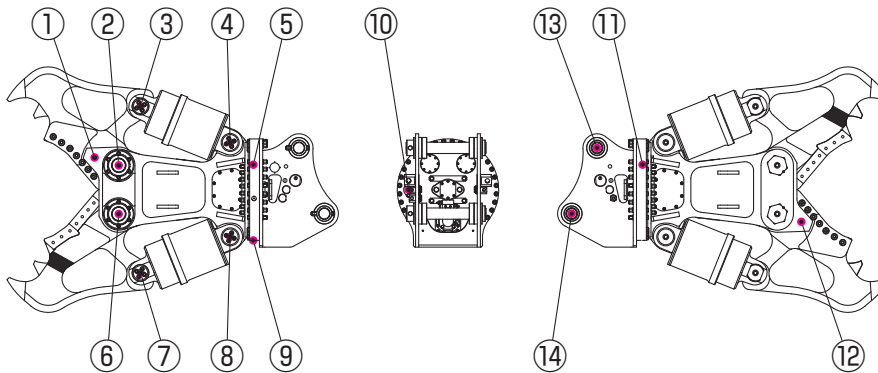

* The presence of ⑬ and ⑭ depends on the installation model.

- DX-SRC-352S

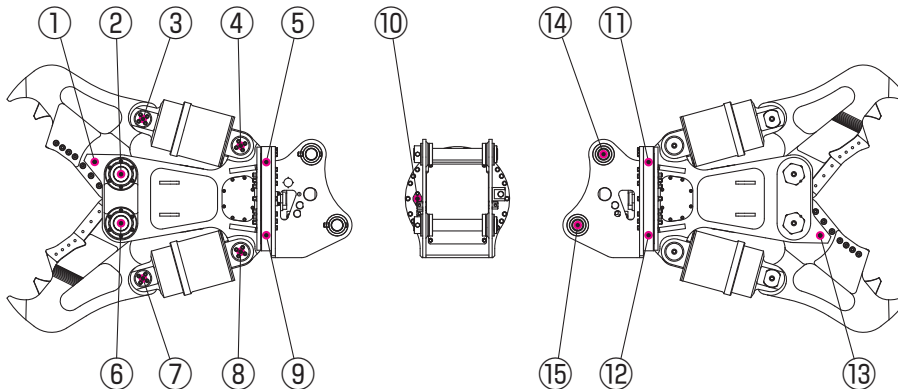

* The presence of ⑭ and ⑮ depends on the installation model.

• Automatic rotation type (A type)

• DX-SRC-135A

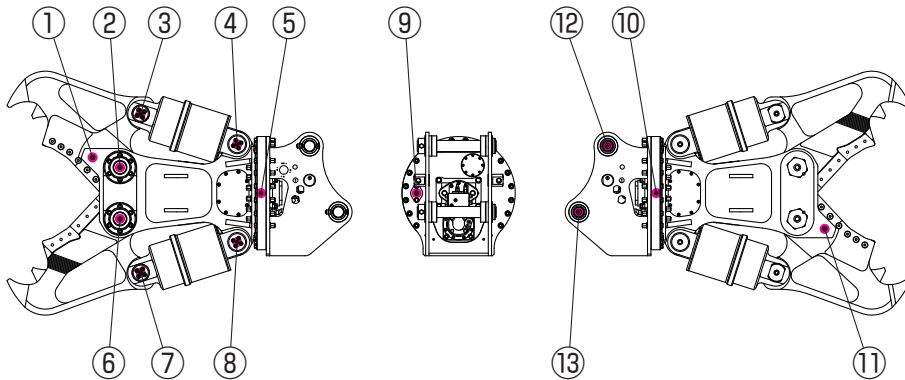

* The presence of ⑫ and ⑬ depends on the installation model.

• DX-SRC-212A

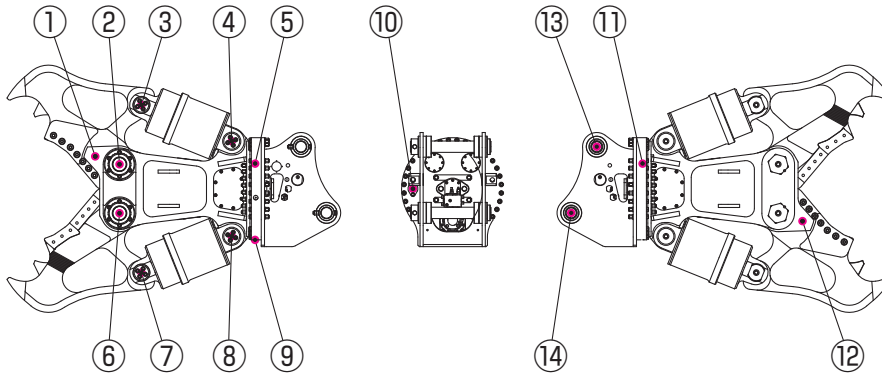

* The presence of ⑬ and ⑭ depends on the installation model.

• DX-SRC-352A

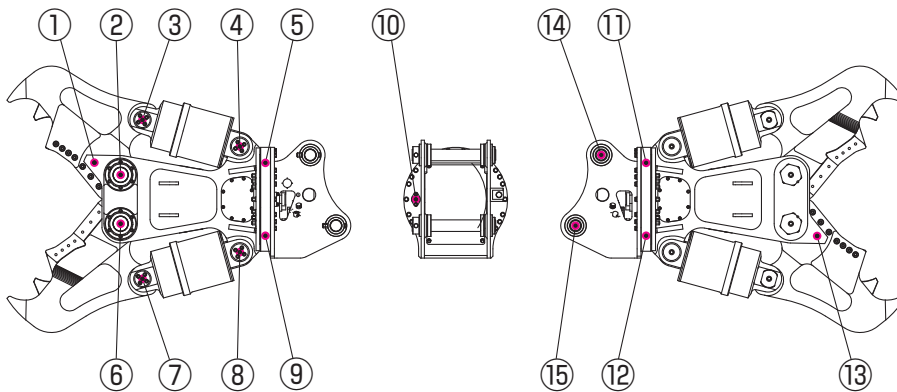

* The presence of ⑭ and ⑮ depends on the installation model.

• Automatic/hydraulic rotation type (AS type)

• DX-SRC-72AS

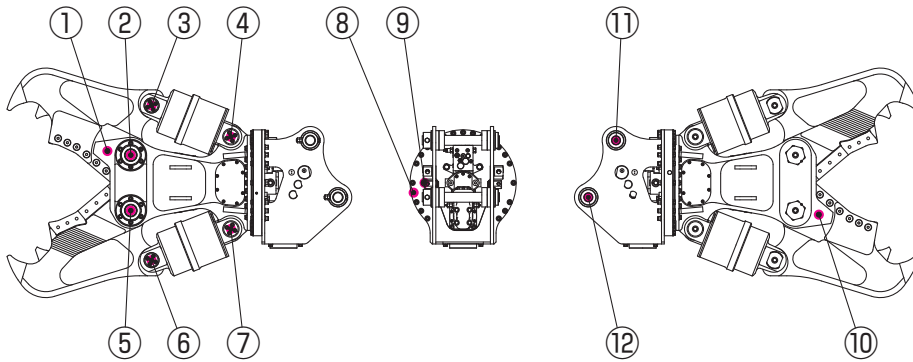

* The presence of ⑪ and ⑫ depends on the installation model.

• DX-SRC-135AS

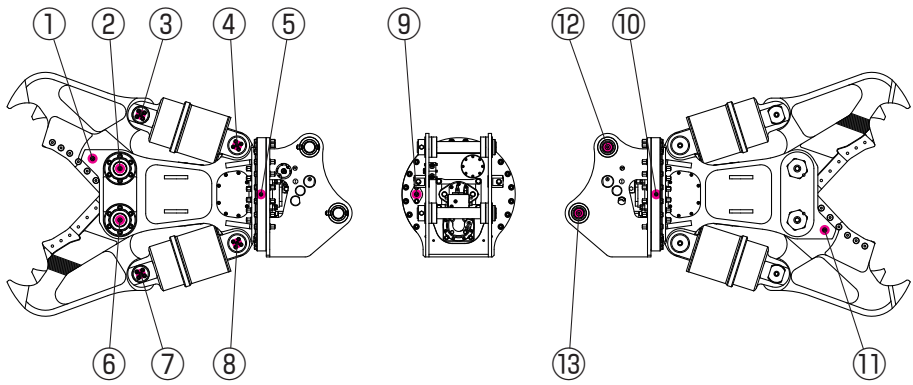

* The presence of ⑫ and ⑬ depends on the installation model.

• DX-SRC-212AS

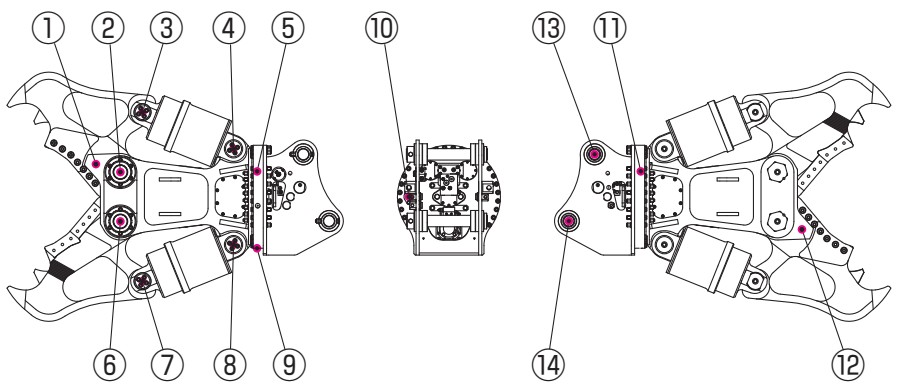

* The presence of ⑬ and ⑭ depends on the installation model.

• DX-SRC-352AS

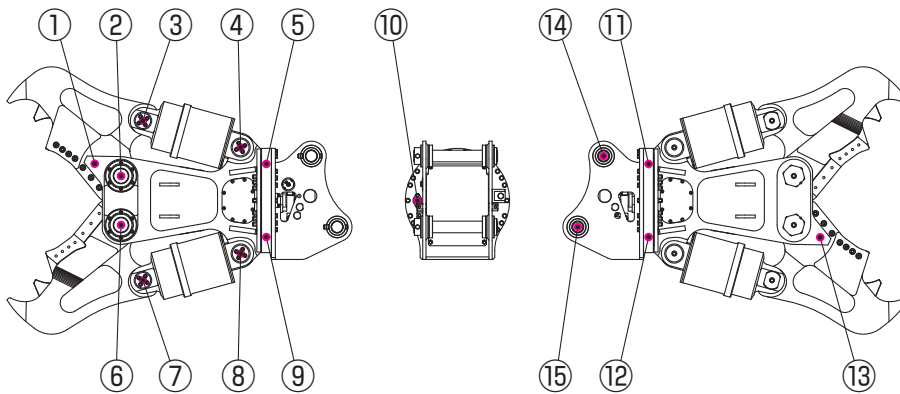

* The presence of ⑭ and ⑮ depends on the installation model.

Warm-up operations

When the attachment is new or has just been overhauled, always apply grease and run warm-up operations to release the air in the hydraulic circuit and spread grease before starting work.

Notice

If warm-up operations are not run, there is a risk that the hydraulic equipment of the hydraulic excavator and attachment may be seriously damaged or the moving parts of the attachment may seize.

- 1 Add a sufficient amount of grease to the lubrication points.
For the lubrication points, see "Greasing" (P.53).
- 2 Set the rotation of the engine to low idling, and then slowly move the jaw between fully closed and fully opened about five times at the front.
The air of the hydraulic circuit is released.

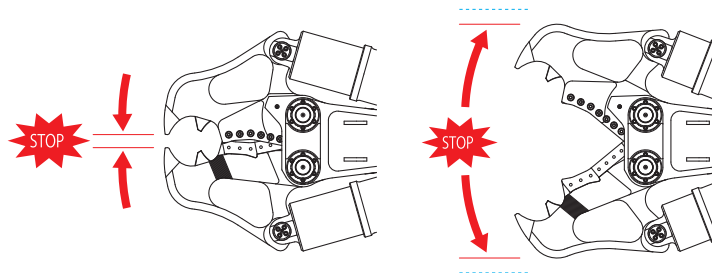
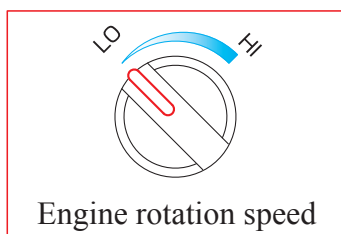

- 3 Add grease one more time.

- 4 At half stroke, move the jaw slowly from fully closed to fully opened about five times.

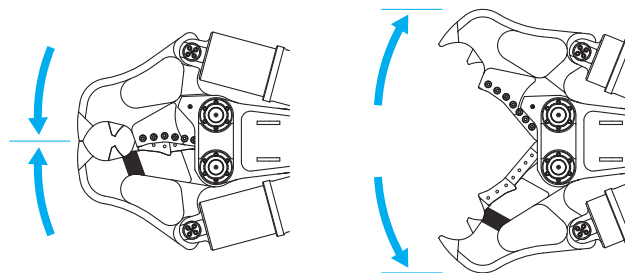
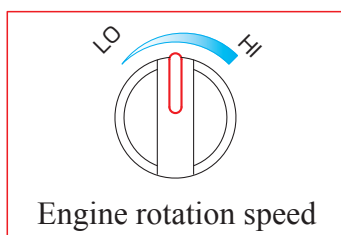

- 5 At half stroke, rotate the attachment about five times.

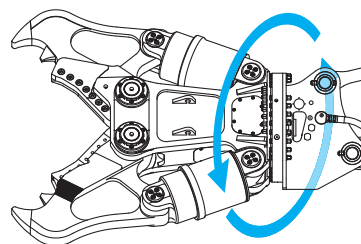
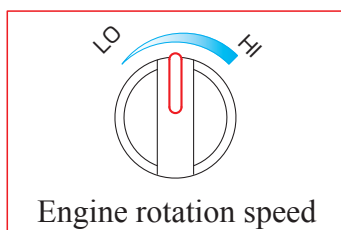

- 6 Warm-up operations are complete.

Adjusting the rotation speed of the attachment (S type, AS type: S mode)

In the case of a hydraulic rotation type (S type) model or an automatic/hydraulic rotation type (AS type) set to S mode, the rotation speed can be changed by the flow rate adjustment valve (slow return check valve) in the bracket. Use at a rotation speed of about 10 to 20 rpm.

Two flow rate adjustment valves (slow return check valves) are installed for right rotation and the left rotation.

*The rotation speed of DX-SRC-72AS cannot be adjusted.

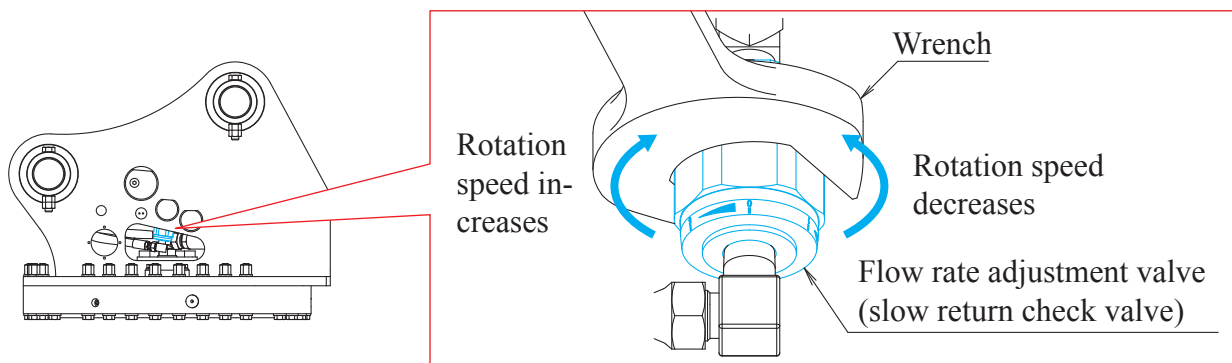

Notice

- Stop the engine of the hydraulic excavator, and then release the internal pressure inside the hydraulic circuit before adjusting the rotation speed.
- Do not adjust the rotational speed when there is residual pressure. Otherwise, the attachment may be damaged. For the procedure to relieve the internal pressure, see "Releasing internal pressure of hydraulic circuit to prevent high-temperature/high-pressure oil spouting" (P.66) of the Inspection/Maintenance section.

Troubleshooting during attachment installation

If there is a problem with the operating conditions of machinery when the attachment is installed, check the relevant location using the table below.

Note that the check items differ depending on the manufacturer or model of the hydraulic excavator. For details, see the manual of the hydraulic excavator.

| Problem | Check item |
|---|--|
| Jaw does not move | <ul style="list-style-type: none"> • Is the work mode of the hydraulic excavator in crusher mode (in the case of automatic switching piping)? • Is the manual switching valve set to the crusher side (in the case of manual switching piping)? • Has the lock lever of the hydraulic excavator been released? • Has the lock pin of the operation pedal been released or is there a foreign object under the pedal? • Are the stop valves of the piping of the hydraulic excavator set to ON (fully open)? |
| The jaw moves arbitrarily | <ul style="list-style-type: none"> • Is the work mode of the hydraulic excavator in crusher mode (in the case of automatic switching piping)? • Is the manual switching valve set to the crusher side completely (in the case of manual switching piping)? • Is the lock valve of the accumulator of the piping completely closed? |
| There is a strange noise during opening or closing of the jaw | <ul style="list-style-type: none"> • Has grease been applied? |
| Movement is slow (jaw/rotation) | <ul style="list-style-type: none"> • Are the stop valves of the piping of the hydraulic excavator set to ON (fully open) (jaw/rotation)? • Has it been adjusted to the necessary flow rate? • Has the lock pin of the operation pedal been released or is there a foreign object under the pedal? |
| There is no force | <ul style="list-style-type: none"> • Are the stop valves of the piping of the hydraulic excavator set to ON (fully open)? • Is the necessary oil pressure coming out? |
| There is no hydraulic rotation | <ul style="list-style-type: none"> • Is there a mistake in the hose connection? • Has the lock pin of the operation pedal been released or is there a foreign object under the pedal? • Is the flow rate adjustment valve not closed (in the case of piping with a flow rate adjustment valve)? • Are the stop valves of the piping of the hydraulic excavator set to ON (fully open)? • Is the necessary oil pressure coming out? |

If the problem is not solved by the chart above, there may be a breakdown of the hydraulic excavator or attachment.

- Do not use machinery while the problem remains. Contact your Taguchi dealer immediately.
- Regarding inspections and adjustments of the oil pressure, flow rate, and other items, consult with the place of purchase of the hydraulic excavator.

Removing the attachment

Warning

When you remove the attachment, always release the residual pressure of the hydraulic piping before removing the hydraulic hose. If there is residual pressure in the circuit, high-temperature oil may shoot out, which is very dangerous. For the procedure to relieve the internal pressure, see "Releasing internal pressure of hydraulic circuit to prevent high-temperature/high-pressure oil spouting" (P.66) of the Inspection/Maintenance section.

- 1 Choose a location with a flat solid surface, and place the attachment stably on a support stand, rectangular lumber, etc. with the jaw of the attachment fully open.

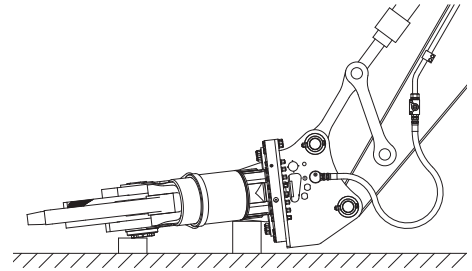

- 2 Stop the engine of the hydraulic excavator, and then release the internal pressure inside the hydraulic circuit.

For the procedure to relieve the internal pressure, see "Releasing internal pressure of hydraulic circuit to prevent high-temperature/high-pressure oil spouting" (P.66) of the Inspection/Maintenance section.

- 3 After making sure that the hydraulic oil has cooled, set the orientation of the arrows of the stop valve of the hydraulic excavator as shown in the illustration to set the valve to OFF (fully closed).

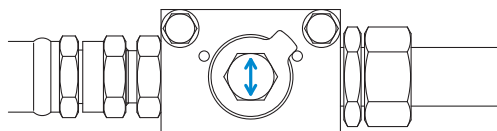

Stop valve fully closed

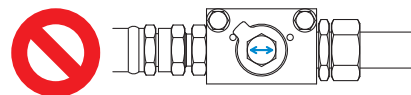

Stop valve fully open

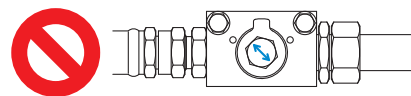

Stop valve half open

- Remove the connection hydraulic hose, and then install the hose plugs on both ends of the hydraulic hose and the caps on the piping port block of the attachment and the stop valve of the hydraulic excavator.

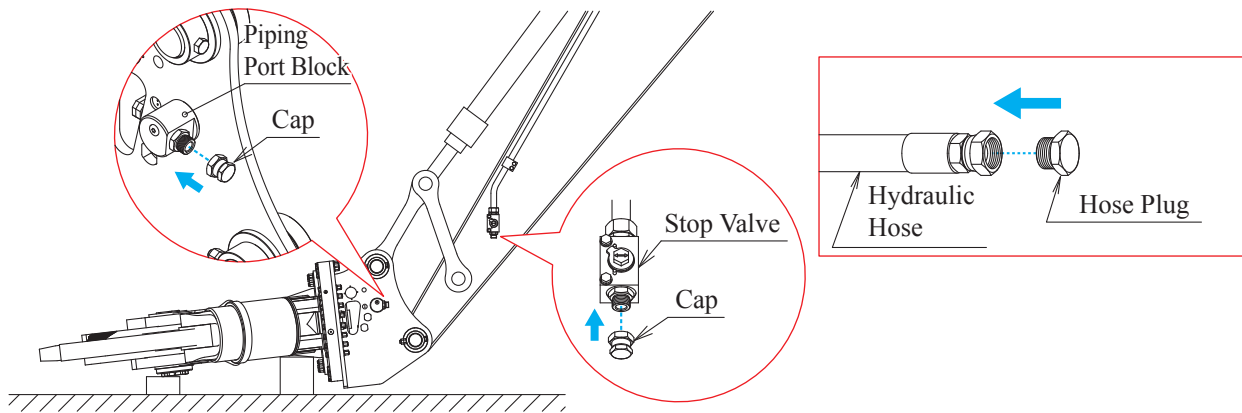

Notice

- The hose plugs of the connection hydraulic hose and the caps of the piping port block of the attachment and the stop valve of the hydraulic excavator are intended to prevent waste and dust from entering the hydraulic circuit and causing a breakdown. After removing the hydraulic hose, tighten and store the hose plugs and caps reliably.

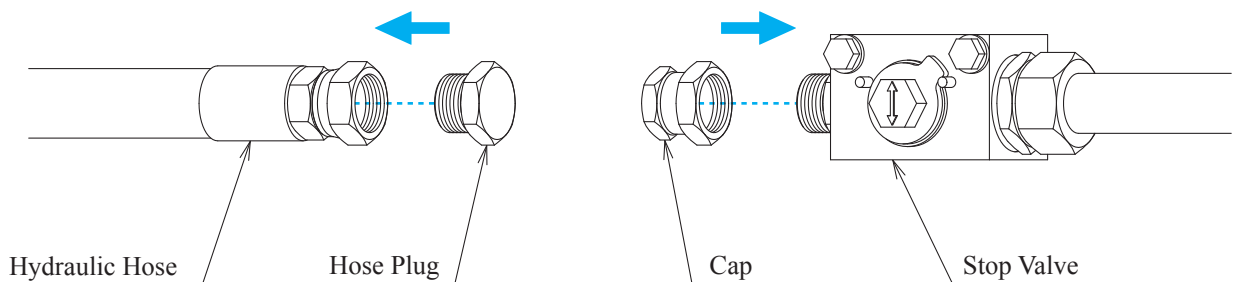

- Always use a hose plug and stop valve cap that are the same type and size. Installing other types and sizes may lead to oil leaks.

(Example)

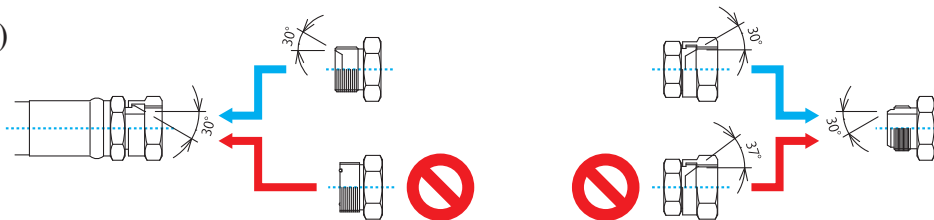

- 5 Remove the installation pin on the bucket link side of the hydraulic excavator (a).

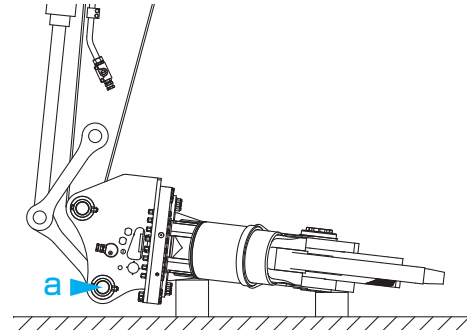

- 6 Remove the installation pin on the stick tip side of the hydraulic excavator (b).

When the installation pin cannot be removed, start the engine of the hydraulic excavator, carefully operate the hydraulic excavator stick and bucket link while centering the installation hole on the hydraulic excavator side and the installation hole on the attachment side.

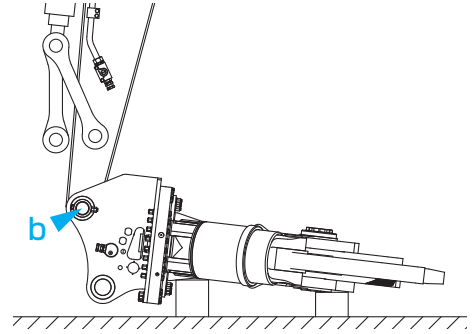

- 7 The removal procedure is complete.
When the attachment will be stored for a long time, add grease to all lubrication points.

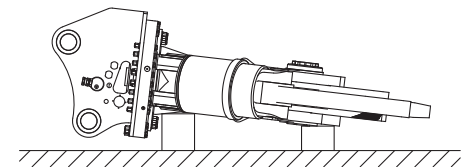

Inspection and Maintenance

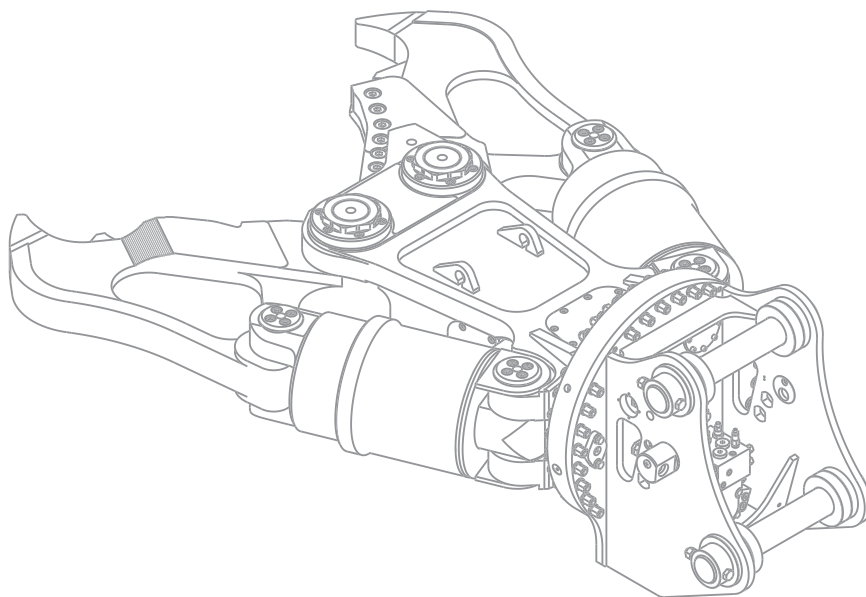

Warning

Before working based on the items explained in this section, first sufficiently understand the content and important points of the Safety (P.11) and Operation (P.31) sections.

Releasing internal pressure of hydraulic circuit to prevent high-temperature/high-pressure oil spouting

Warning

Because there is always internal pressure in the hydraulic system, always release the pressure in the circuit before inspecting or replacing piping and hoses or installing or removing the attachment from the hydraulic excavator (base machine). If the pressure is not released, high-temperature/high-pressure hydraulic oil may spout and lead to a serious accident resulting in personal injury or death.

Internal pressure release procedure

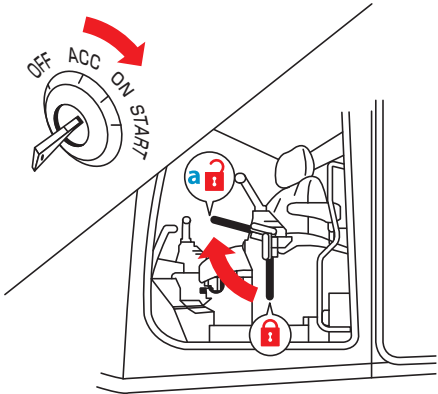
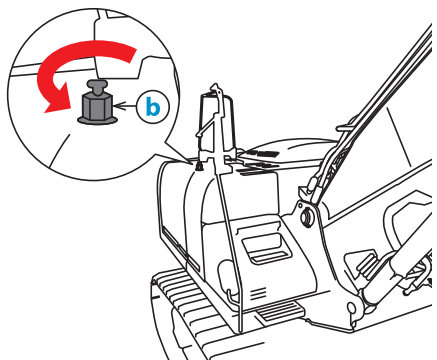
- 1 Always place the attachment on a stand, rectangular lumber, or other similar item on a solid flat surface, and then stop the engine.
- 2 Set the start switch to the ON position, and then set the lock lever to the free (a) position.
 
- 3 Perform a full stroke operation two or three times by moving the lever and pedals for each working equipment (boom and stick)/attachment operation front and back and left and right.
- 4 Slowly loosen the cap of the fuel filler opening on top of the hydraulic oil tank (b) to release the internal pressure.
 

Warning

The procedure above is an example. The procedure may be slightly different depending on the model of hydraulic excavator. For details, see the manual of the hydraulic excavator to be used.

Retightening of bolts, nuts, and hydraulic hoses

Warning

After eight hours have passed from the start of use of a new product, check the retightening of all bolts, nuts, and hose caps. Retighten any loose items.

Always check for loose or missing bolts, nuts, and hydraulic hoses during the inspection before start of work.

Retightening examples

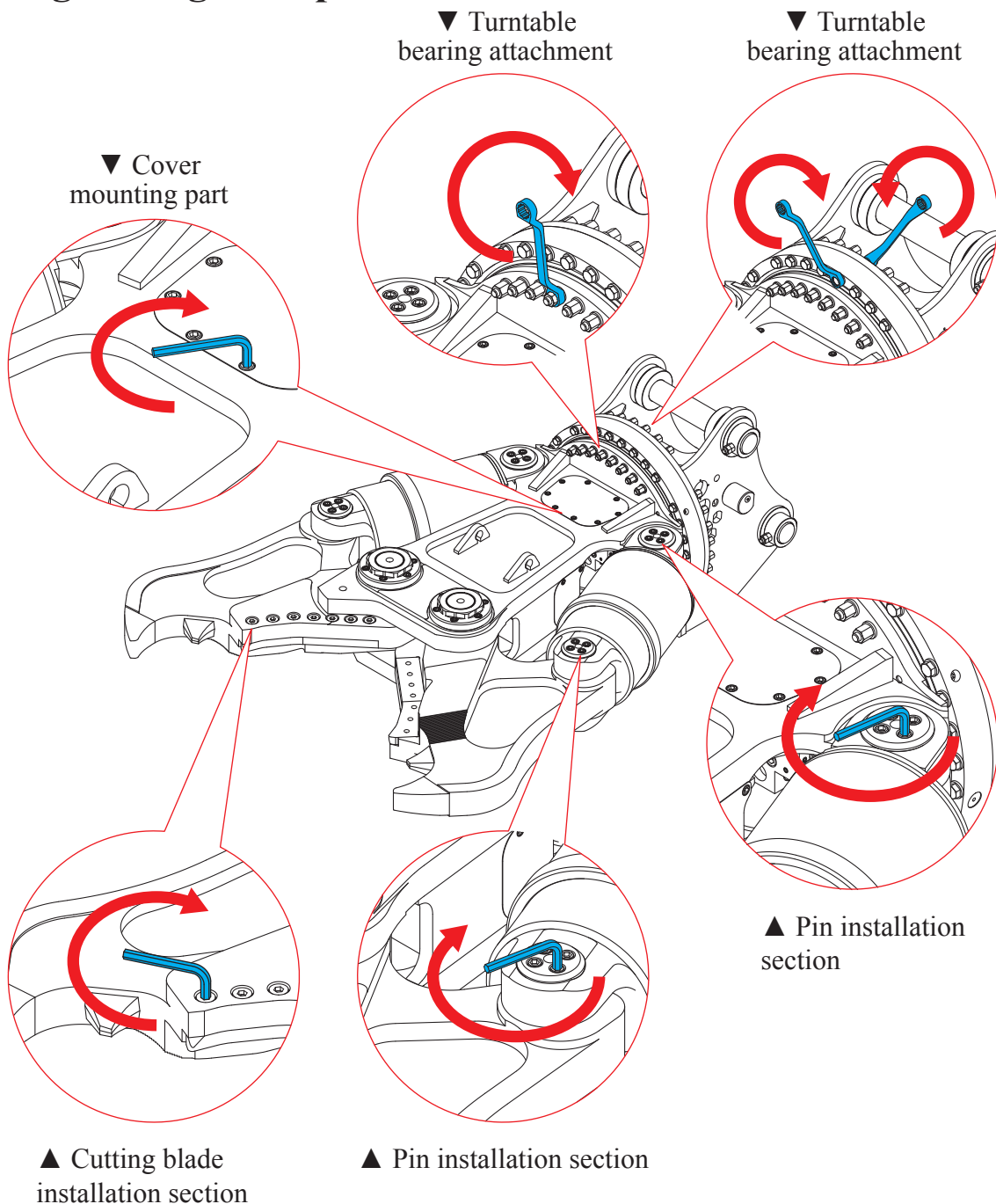

Always retighten using the prescribed torque. For the prescribed torque, see the standard torque table.



Warning

Retighten the turntable bearing bolt

When the attachment is being used, do not perform strong striking work or pull strongly with the attachment. Strong forces will act on the turntable bearing and damage the bearing and bolts, and there is a risk of a serious accident, for example, due to the dropping of the attachment.

Furthermore, damage of the rotation section may affect surrounding parts (swivel joint, brake device, hydraulic piping, etc.) and result in large repair costs.

Standard torque table

| Size | Tightening torque (N · m) | Tightening torque (kgf · m) |
|------|---------------------------|-----------------------------|
| M8 | 37.2 | 3.8 |
| M10 | 72.5 | 7.4 |
| M12 | 128 | 13.1 |
| M14 | 204 | 20.8 |
| M16 | 313 | 31.9 |
| M18 | 450 | 45.9 |
| M20 | 620 | 63.3 |
| M22 | 825 | 84.2 |
| M24 | 1060 | 108 |
| M27 | 1530 | 156 |
| M30 | 2090 | 213 |

Adjusting the gap of the jaw of the attachment

Wear of the bushings of the jaw of the attachment from long-term use create gaps between the jaw and the main frame. If there is a gap in the jaw, the cutting ability of the attachment will drop and the pins will be damaged. Therefore, periodically inspect and adjust the gap of the jaw.

Adjusting using the nuts

1 Remove all screw plugs and lock bolts from the nuts.

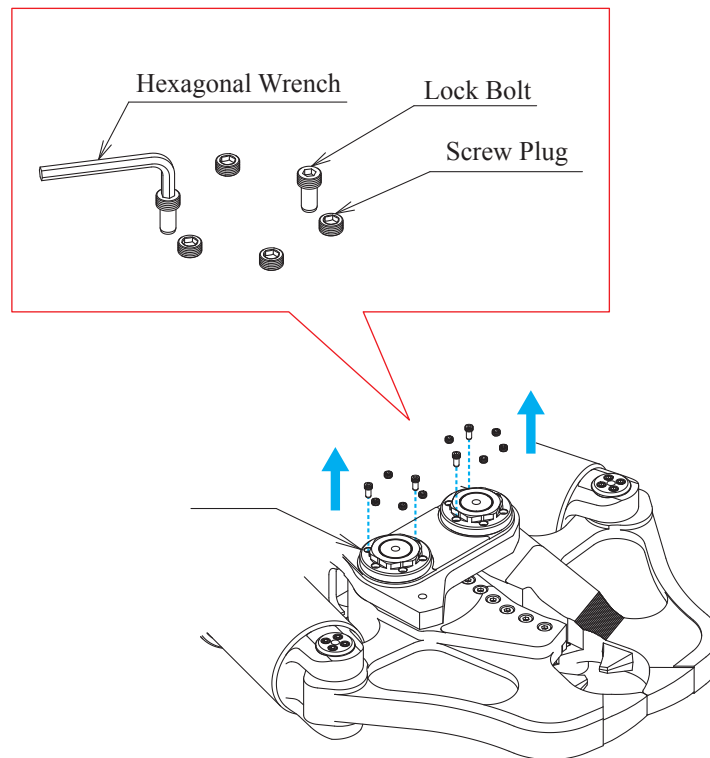

Caution

Two lock bolts are attached to each nut. Always remove all lock bolts.

2 Turn the nut to adjust the gap of the jaw so that the nut hole position and the main frame hole position match.

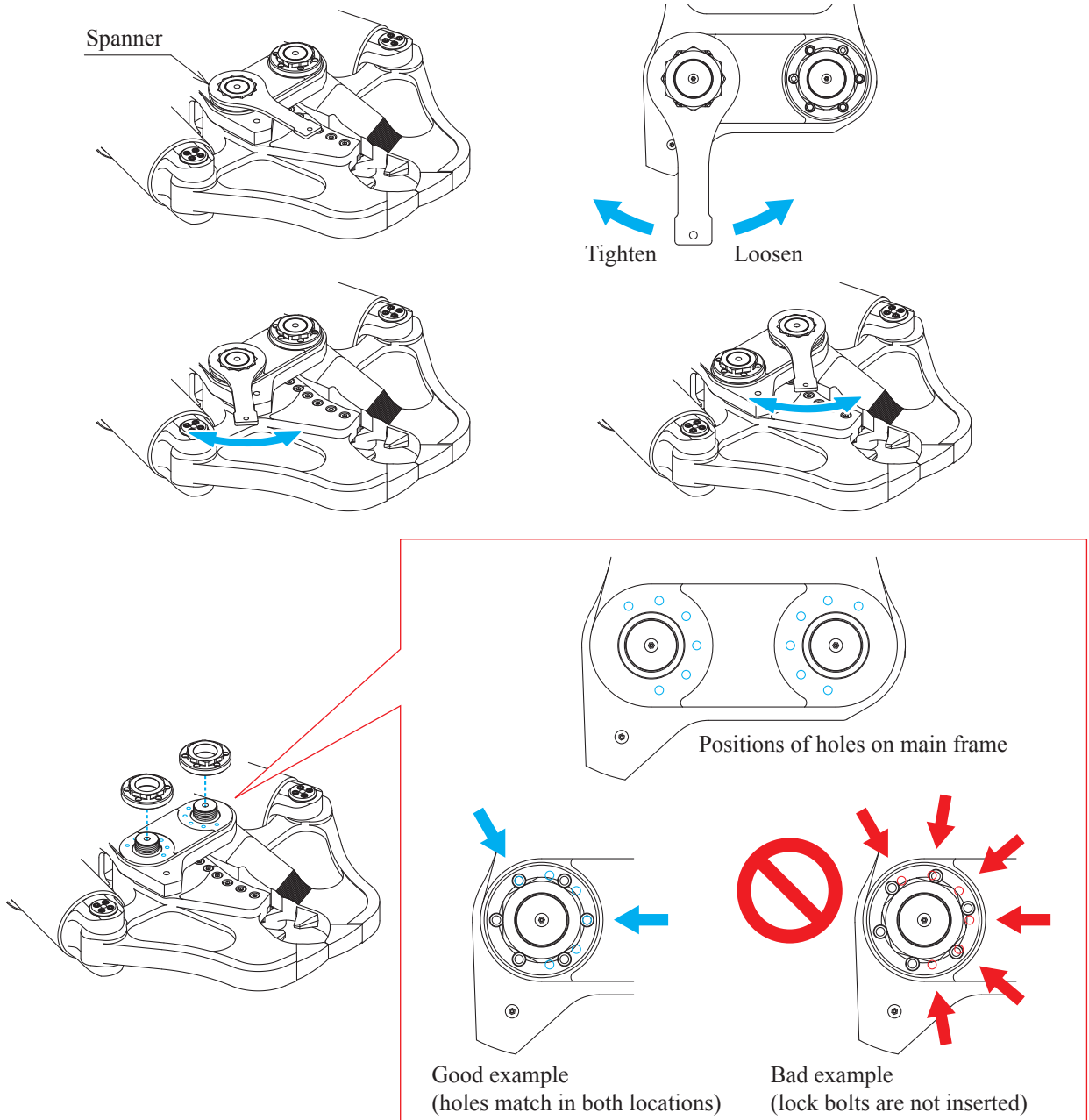

* Watch for damage due to excessive nut tightening.

3 Install the lock bolts and screw plugs.
The adjustment procedure is complete.

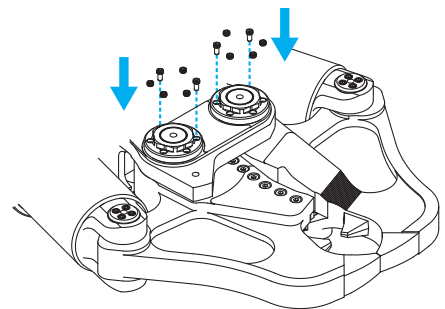

Inspecting the cutting blades

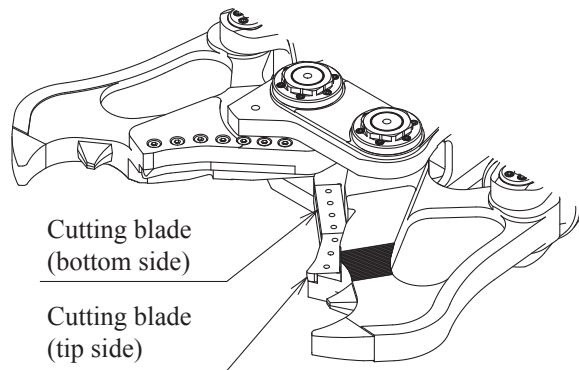

Notice

See the following section for wear and gaps of the cutting blade. If the range has been exceeded, stop use and adjust adding the shim(s) or replace the cutting blade.

■ Wear limit of cutting blade (bottom side)

If the edge of the cutting blade has been worn and become rounded, use a grinder to sharpen the edge.

* Four sides of the cutting blade can be used. Use by reversing or rotating.

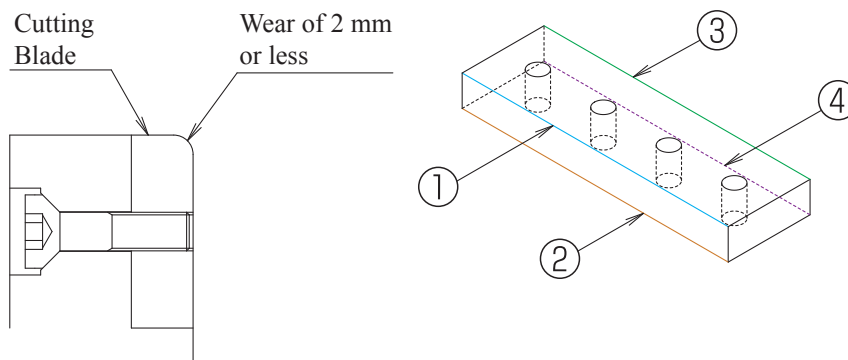

■ Wear limit of cutting blade (tip side)

If the edge of the cutting blade has been worn and become rounded, reverse the blade before use.

* Two sides of the cutting blade can be used.

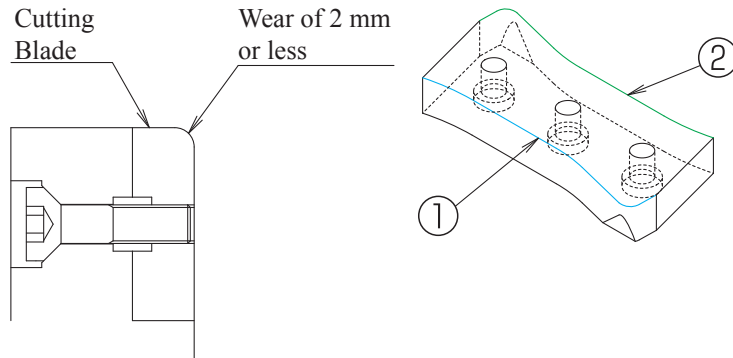

Warning

Do not repair the worn section of the cutting blade by welding. Otherwise, the cutting ability of the cutting blade will drop, which may cause an accident or attachment damage.

■ Adjusting the gap of the cutting blades

After adjusting the gap of the jaw of the attachment (P.69), insert a shim to adjust the gap of the cutting blades.

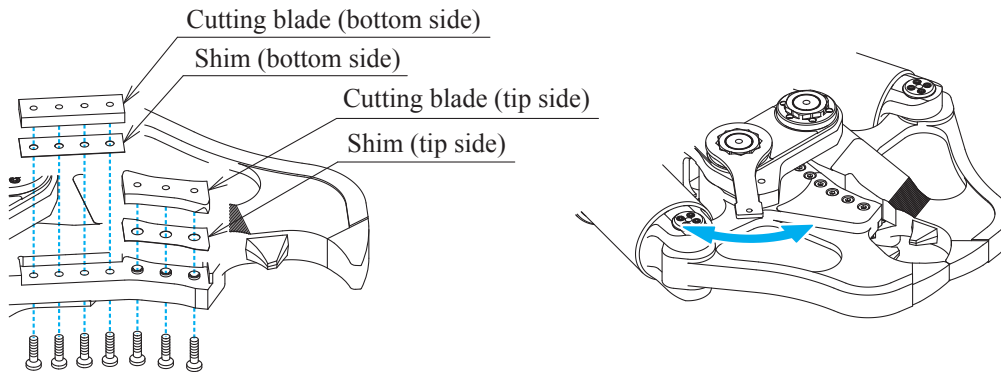

If the gap of the cutting blades exceeds **2 mm** on both the bottom side and tip side, adjust the gap so that it is within **0.5 mm**.

● Bottom side

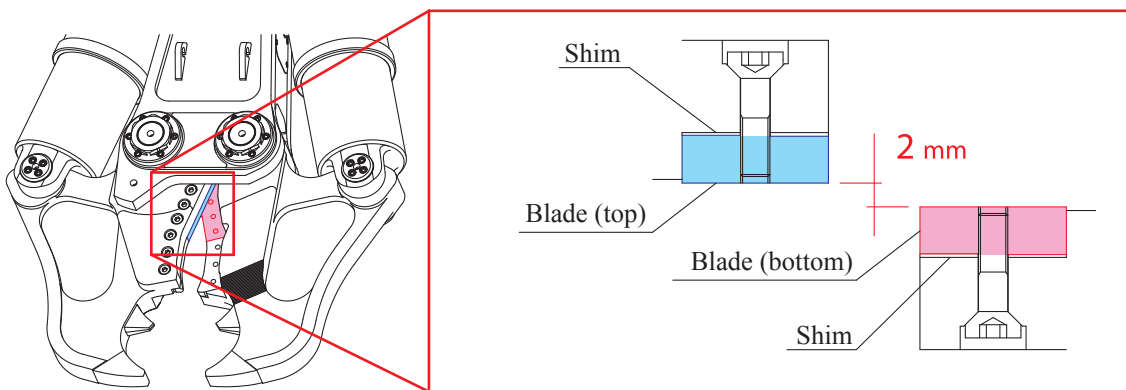

● Tip side

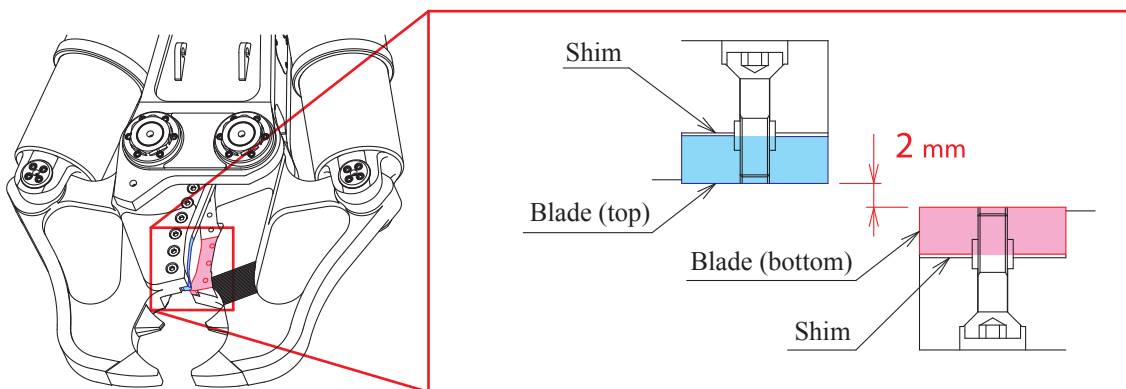

When the total of the shims used more than **2 mm**, repair is necessary.

Good example:

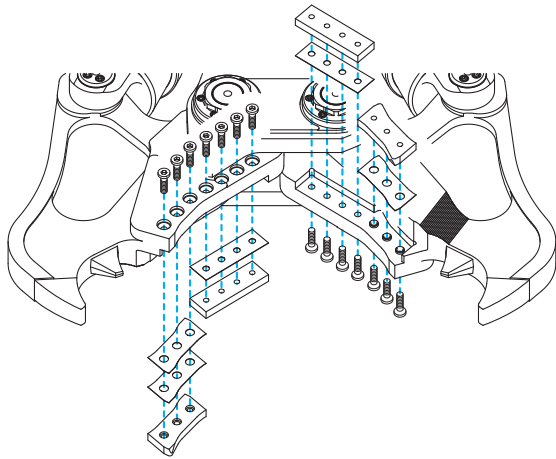

| | |
|--|------------------|
| Total of blade-bottom left-side shims | :0.6 mm |
| Total of blade-bottom right-side shims | :0.6 mm |
| <hr/> | |
| Total of blade-bottom shims | :1.2 mm < 2.0 mm |

| | |
|-------------------------------------|------------------|
| Total of blade-tip left-side shims | :1.2 mm |
| Total of blade-tip right-side shims | :0.6 mm |
| <hr/> | |
| Total of blade-tip shims | :1.8 mm < 2.0 mm |

Bad example:

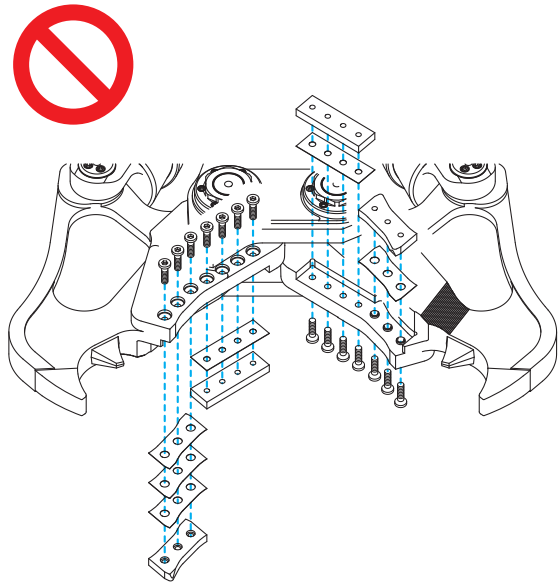

| | |
|--|------------------|
| Total of blade-bottom left-side shims | :0.6 mm |
| Total of blade-bottom right-side shims | :0.6 mm |
| <hr/> | |
| Total of blade-tip shims | :1.2 mm < 2.0 mm |

| | |
|-------------------------------------|--------------------------|
| Total of blade-tip left-side shims | :1.8 mm |
| Total of blade-tip right-side shims | :0.6 mm |
| <hr/> | |
| Total of blade-tip shims | : 2.4 mm ≥ 2.0 mm |

Notice

When installing a tip-side cutting blade, do not forget to attach the bushings.

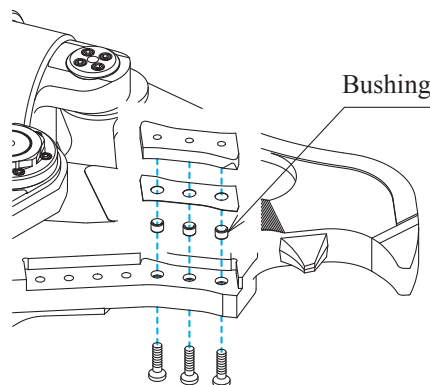

Repair welding

Teeth and other parts become worn following crushing work by the attachment. When there is a lot of wear, not only does the crushing performance drop, the attachment may malfunction or become damaged. In such cases, perform repair welding.

Caution

Remove moisture, rust, slag, paint, and other items on the welding surface before welding. When the welding materials or heat management (pre-heating or post-heating) are inappropriate, cracks may occur in the welding.

If the attachment becomes worn, weld or build up as shown below. If there is a lot of wear, repair or replacement is necessary. Consult with your Taguchi dealer.

Welding must be carried out by a qualified person.

Perform welding indoors in an area free of drafts.

Notice

Replace or buildup the teeth using prescribed welding rods with proper heat management.

■ Repairing teeth

Special abrasion-resistant material is used for teeth. If careless buildup or surface hardening buildup with fine hairline cracks is performed, not only will the teeth crack, but the crack may reach down to the jaw base material.

When the teeth are worn, cut the old teeth, and then weld new teeth.

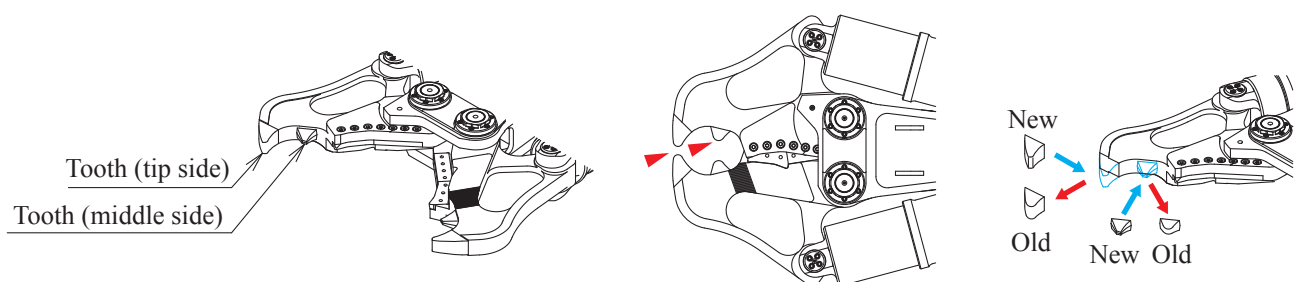

● Welding teeth

Use a welding rod of JIS Z 3211 E5716-U H10 or equivalent.

① Drying of welding rods

Before use, dry welding rods from 350 through 400°C for about 60 minutes.

② Preheating of base material

Before welding, preheat the base material from 50 through 100°C.

③ After welding, retain heat and do not cool rapidly.

■ Buildup repair of worn areas

Before welding, remove dirt, oil, rust, and other items on the area to be repaired, and then preheat the area to 200°C or higher.

Weld at an interpass temperature of about 200°C. After welding, use a grinder to form the shape, and then post-heat to 200°C or higher. Next, slowly cool the welding area by wrapping it with an incombustible heat-installation sheet.

For post-heating in winter and cold regions, slowly cool the whole jaw by wrapping it with an incombustible heat-insulation sheet, and take care not to rapidly cool the welded part.

● Repair of worn areas

(1) Primary buildup welding

Perform primary buildup welding on locations that are badly worn, and then perform hard facing on top of this. In principle, perform hard facing for one layer of the surface.

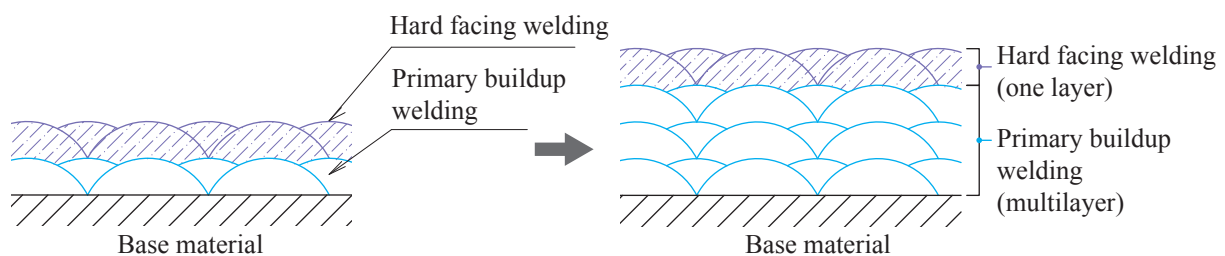

Multilayer welding of hard facing causes cracks.

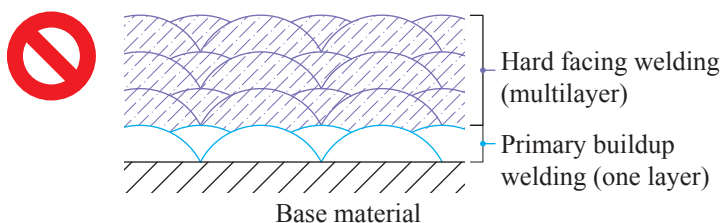

Use a welding rod of JIS Z 3211 E5716-U H10 or equivalent.

① Drying of welding rods

Before use, dry welding rods from 350 through 400°C for about 60 minutes.

② Preheating of base material

Before welding, preheat the base material from 50 through 100°C.

③ After welding, retain heat and do not cool rapidly.

(2) Hard facing welding

Use hard facing welding to repair worn areas and improve wear resistance.

Use a welding rod of JIS Z 3251 DF3C or equivalent.

① Drying of welding rods

Before use, dry welding rods from 350 through 400°C for about 60 minutes.

② Preheating of base material

Before welding, preheat to the base material to 200°C or higher.

③ After welding, heat and keep at 400°C.

• Repair of jaw worn areas

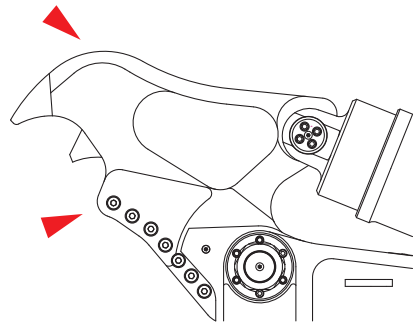
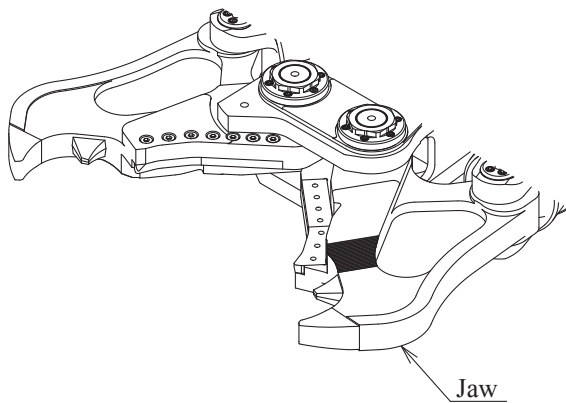

Hard facing welding

Use hard facing welding to repair worn areas and improve wear resistance.

As a rule for buildup repair, form only one layer of hard facing, and do not perform primary buildup welding.

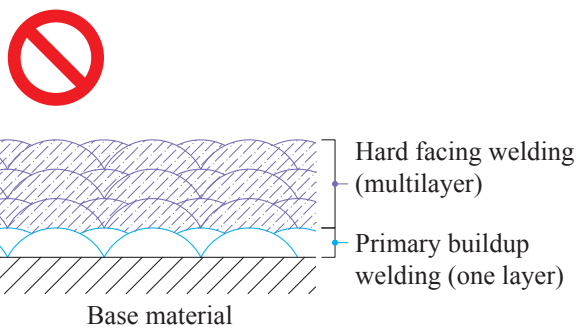
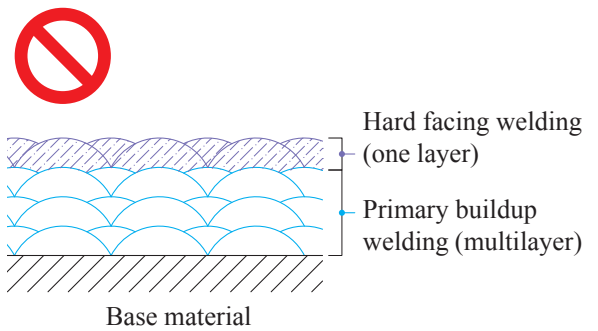
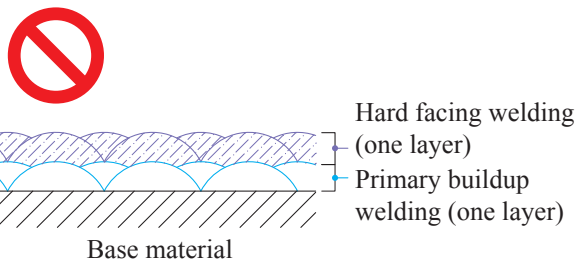
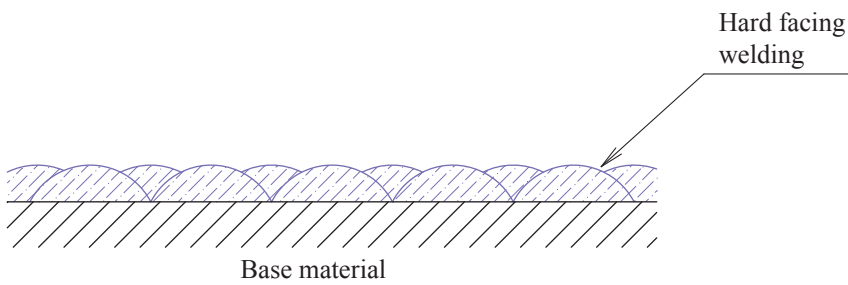

Use a welding rod of JIS Z 3251 DF3C or equivalent.

① **Drying of welding rods**

Before use, dry welding rods from 350 through 400°C for about 60 minutes.

② **Preheating of base material**

Before welding, preheat the base material to 200°C or higher.

③ **After welding, heat and keep at 400°C.**

 **Warning**

Do not repair the worn section of the cutting blade by welding. Otherwise, the cutting ability of the cutting blade will drop, which may cause an accident or attachment damage.

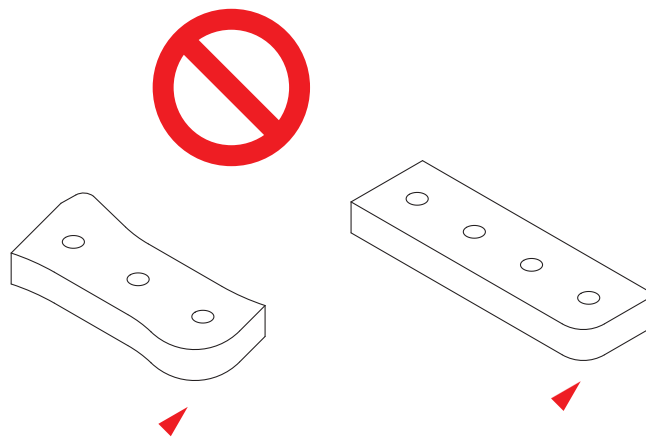

Storage



Warning

- Store the attachment in a stable condition so that it does not fall over.
 - Take measures so that children, third parties, and other unauthorized people cannot enter the storage area, such as by using a lock.
-
- ① Do not store the attachment in a location exposed to rain. Store the attachment indoors. If the attachment will be stored outdoors, place it in a safe location on rectangular lumber and cover it with a sheet or similar item.
 - ② If the attachment will be stored by itself, install dust plugs on the ends of hydraulic hoses to prevent foreign objects to get into.
 - ③ When the attachment will not be used for a long time, add grease to specified locations. Furthermore, always store the attachment with the jaw open. Before starting work after long-term storage, carry out the procedure of “Inspection and maintenance before start of work”.
 - ④ During storage, do not release the hydraulic oil inside the attachment.

Cautions during transport

- Before transporting the attachment, remove it from the hydraulic excavator.
- During transport, set the attachment in a stable state and fasten it securely with wire ropes, chains, or similar items.
- Install dust plugs on the ends of hydraulic hoses to prevent the ingress of waste.

Lifting the attachment

1 Fully open the jaw of the attachment, and then attach shackles and wire ropes securely to the two rings of the main frame.

It is dangerous to use a hanger that does not satisfy the permissible hanging load or use lifting methods that cause the attachment to become unstable, such as using a single hanger.

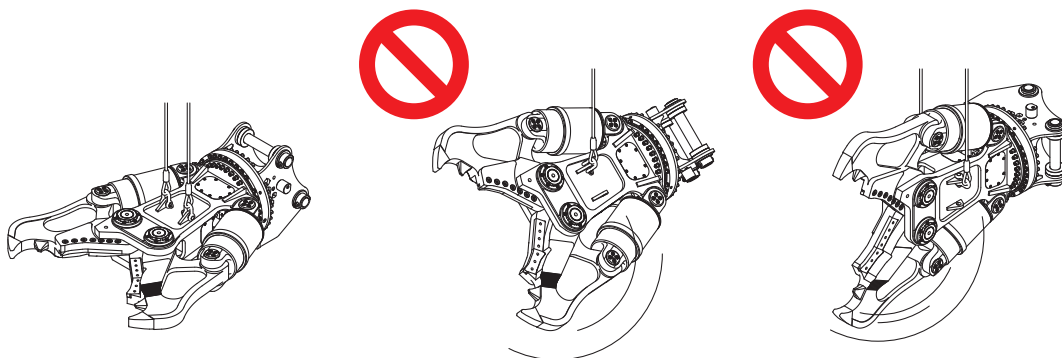
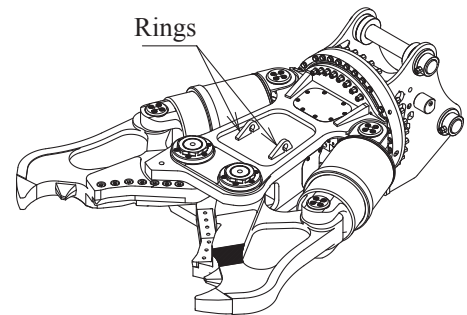

2 After lifting the attachment a few centimeters from the ground, stop temporarily and wait for the attachment to stabilize before raising it up slowly.

Make sure that the attachment does not tilt or shake while it is being lifted.

Periodical maintenance

Inspection locations are classified by inspection intervals. Follow the content of the regular maintenance table. Immediately repair any problems that are found.

Periodical maintenance table

Comply separately with any mandatory inspections particular to the country of use.

| Class | Inspection location/content | Inspection frequency | | | | Reference |
|-------------------|---|----------------------|---------------------------------|------------------------------------|-------------------|-----------|
| | | Inspection by user | | Inspection by qualified person (*) | | |
| | | First 8 hours | Inspection before start of work | Monthly inspection | Annual inspection | |
| Exterior | Bracket, main frame (upper/lower frame) Cracks, deformations, wear | — | ○ | ○ | ○ | P.38 |
| | Pins, spacers, collars, bushings Cracks, deformations, wear, rattling | — | ○ | ○ | ○ | |
| | Bolts, nuts Breakage, bending, looseness, loss | Retightening | ○ | ○ | ○ | |
| | Cover, cylinder guard Cracks, deformations, wear, loss | — | ○ | — | — | |
| Rotation devices | Turtable bearing (bearing), gear (rotation gear) Cracks, wear (gear cracks/wear), catching, abnormal noises, dust-seal damage/loss, installation, operation problems | — | ○ | ○ | ○ | |
| Hydraulic devices | Hydraulic motor Cracks, oil dirt, oil leaks, abnormal vibrations, abnormal noises, abnormal heat generation, operation problems | — | ○ | ○ | ○ | |
| | Swivel joint (rotation joint) Cracks, oil dirt, oil leaks, abnormal noises, operation problems | — | ○ | ○ | ○ | |
| | Hydraulic piping (hydraulic hoses, hydraulic joints, high-pressure pipes) Cracks, deterioration (aging), damage, fissures, twisting, looseness, oil dirt, oil leaks, installation, loss | — | ○ | ○ | ○ | |
| | Hydraulic cylinder, opening/closing cylinder Cracks, deformation, operation problems, oil dirt, oil leaks, expansion and contraction amount, dents, bending, corrosion, wear | — | ○ | ○ | ○ | |

| Class | Inspection location/content | Inspection frequency | | | | Reference |
|------------------------------|--|----------------------|---------------------------------|------------------------------------|-------------------|---------------|
| | | Inspection by user | | Inspection by qualified person (*) | | |
| | | First 8 hours | Inspection before start of work | Monthly inspection | Annual inspection | |
| Hydraulic devices | Control valve (speed valve block/rotating valve block) Cracks, operation problems, oil dirt, oil leaks, installation | — | ○ | ○ | ○ | P.38 |
| | Stop valve Are the stop valves on both sides of the stick of the hydraulic excavator are fully open? | — | ○ | — | — | |
| Crushing/ Cutting part | Jaw (crushing / cutting jaw) Cracks, deformations, wear | — | ○ | ○ | ○ | P.38, P.69 |
| | Cutting blade (cutter) Cracks, fragments, wear, installation, gaps, loss | — | ○ | ○ | ○ | P.38, P.71 |
| | Teeth (crushing point) Cracks, loss, rattling, wear | — | ○ | ○ | ○ | P.38, P.75 |
| Greasing | Apply grease to specified locations (first application is before delivery; after this apply at least twice a day (every four hours), including before the start of work) | ○ | ○ | ○ | ○ | P.38 P.53 |
| Hydraulic oil | Insufficient hydraulic oil amount, presence of contamination | — | ○ | — | — | P.38 |
| Display | Notice boards Nameplates/safety labels (caution plates) Legibility/loss of text/diagrams | — | ○ | ○ | ○ | P.6 |
| Operation | Operation levers of hydraulic excavator, etc. | — | — | ○ | ○ | P.38 |
| Excavator body | Flying-object protection devices Are all covers installed? | — | ○ | ○ | ○ | |
| Overall attachment operation | Operation problems, abnormal noises, abnormal vibrations | — | ○ | — | — | |
| General | General test | — | — | ○ | ○ | |

* The inspection table above is provided to users as a reference. It is based on the designated self-inspection system established by the Industrial Safety and Health Law of Japan and the repair and maintenance field particular to Taguchi. The inspection items of designated self-inspections carried out by qualified people may change without notice. For the latest information, refer to the website of the Safety Association of Construction and Loading Vehicles in Japan.

Items replaced periodically

| Inspection part | Inspection content | Measure | Inspection interval |
|-----------------|--------------------|-------------|--------------------------|
| Hydraulic Hose | — | Replacement | 4,000 hours or two years |

**Warning****Periodic replacement of hydraulic hoses**

- To ensure that the machinery can be used safely for a long time, periodically exchange hydraulic hoses, which are particularly related to safety and fire.
- The material of the hydraulic hose changes over time, and wear and deterioration occur easily. Because it is difficult to determine the extent through periodic maintenance, after a certain usage period, it is necessary to replace old parts with new ones to maintain constant and complete functionality, even when problems have not been discovered.
- Hydraulic hoses must be repaired or replaced before the replacement term in the unlikely event that some problem is discovered. Note that when deformation, cracking, or other deterioration of the hose clamp has been found, the clamp must also be exchanged.
- Ask your Taguchi dealer to replace hydraulic hoses.

When replacing hydraulic hoses, replace the O-rings and seals with new ones at the same time.

Troubleshooting

Many causes overlap when a malfunction of the attachment occurs.

In the event of a breakdown, check both the attachment manual and hydraulic excavator manual to find the cause of each item and carry out its countermeasure. This table is the same for the S type (hydraulic rotation type), A type (automatic rotation type), and AS type (automatic/hydraulic rotation type).

The marks in the "Countermeasure" field indicate the following content.

⊙: Request an inspection from a workshop specified by Taguchi.

●: Request an inspection from a workshop specified for the hydraulic excavator's dealer.

○: The customer performs the inspection countermeasure.

| Condition | Cause | Countermeasure | Remarks |
|---|---|---|--------------------|
| Does not open or close or opens and closes slowly | The stop valves of the hydraulic excavator are not completely open | ○ Open the stop valves of the hydraulic excavator | |
| | The speed valve block is malfunctioning | ⊙ Repair or replace the speed valve block | |
| | The hydraulic cylinder is malfunctioning | ⊙ Repair or replace the hydraulic cylinder | |
| | The pressure or discharge amount of the hydraulic excavator has dropped | ● Inspect the hydraulic excavator unit, and then adjust the pressure or flow rate | |
| Does not rotate or rotation is slow | The stop valves of the hydraulic excavator are not completely open | ○ Open the stop valves of the hydraulic excavator | |
| | The hydraulic motor is malfunctioning | ⊙ Repair or replace the hydraulic motor | |
| | The rotating valve block is malfunctioning | ⊙ Repair or replace the rotating valve block | A/AS type (A mode) |
| | The turntable bearing is malfunctioning | ⊙ Replace the turntable bearing | |
| | The pressure or discharge amount of the hydraulic excavator has dropped | ● Inspect the hydraulic excavator unit, and then adjust the pressure or flow rate | |
| | The slow return check valve is completely closed | ○ Adjust the slow return check valve | S/AS type (S mode) |
| | The A/S switching valve is in hydraulic rotation mode (S mode) | ○ Switch the A/S switching valve to automatic rotation mode (A mode) | AS type (A mode) |

| Condition | Cause | Countermeasure | Remarks |
|--|--|--|--------------------|
| Rotates while the jaw is open | The rotating valve block is malfunctioning | ◎ Repair or replace the rotating valve block | A/AS type (A mode) |
| | The A/S switching valve is in automatic rotation mode (A mode) | ○ Switch the A/S switching valve to hydraulic rotation mode (S mode) | AS type (S mode) |
| Crushing ability has dropped | The speed valve block is malfunctioning | ◎ Repair or replace the speed valve block | |
| | The hydraulic cylinder is malfunctioning | ◎ Repair or replace the hydraulic cylinder | |
| | Teeth are worn | ○ Build up or replace the teeth | |
| | The pressure of the hydraulic excavator has dropped | ● Inspect the hydraulic excavator unit, and then adjust the pressure | |
| Cutting ability has dropped | The cutting blade is worn | ○ Flip or replace the cutting blade | |
| | There is a large gap between cutting blades | ○ Adjust the gap of the cutting blades with a shim | |
| | The cutting blade is chipped or cracked | ○ Exchange the cutting blade | |
| | The speed valve block is malfunctioning | ◎ Repair or replace the speed valve block | |
| | The hydraulic cylinder is malfunctioning | ◎ Repair or replace the hydraulic cylinder | |
| | The pressure of the hydraulic cylinder has dropped | ● Inspect the hydraulic excavator unit, and then adjust the pressure | |
| There is a strange noise during opening or closing | Grease is insufficient | ○ Add grease | |
| There is a lot of rattling | The pin or bushing is worn | ○ Exchange the pin or bushing | |
| | The spacer edge is worn | ○ Retighten the nuts | |

- If the problem is not solved by the chart above, there may be a breakdown of the hydraulic excavator or attachment.
- Do not use machinery while the problem remains. Contact your Taguchi dealer immediately.
- Regarding inspections and adjustments of the oil pressure, flow rate, and other items, consult with the place of purchase of the hydraulic excavator.

Standard torque table



Warning

If the tightening torque is outside the specified range, the tightening section may become damaged or loose, which may lead to a mechanical breakdown, damage, or a serious accident. Take sufficient care when tightening.

Standard torque table

| Size | Tightening torque (N · m) | Tightening torque (kgf · m) |
|------|---------------------------|-----------------------------|
| M8 | 37.2 | 3.8 |
| M10 | 72.5 | 7.4 |
| M12 | 128 | 13.1 |
| M14 | 204 | 20.8 |
| M16 | 313 | 31.9 |
| M18 | 450 | 45.9 |
| M20 | 620 | 63.3 |
| M22 | 825 | 84.2 |
| M24 | 1060 | 108 |
| M27 | 1530 | 156 |
| M30 | 2090 | 213 |

Hydraulic hose coupling tightening torque table



Warning

If the tightening torque is outside the specified range, the hydraulic hose may become damaged or loose, which may lead to an oil leak, mechanical breakdown, or a serious accident. Take sufficient care when tightening.

Hydraulic hose coupling tightening torque table

| Size | Tightening torque (N · m) | Tightening torque (kgf · m) |
|-------|---------------------------|-----------------------------|
| 1/8 | 15 | 1.5 |
| 1/4 | 25 | 2.5 |
| 3/8 | 49 | 5 |
| 1/2 | 59 | 6 |
| 3/4 | 157 | 16 |
| 1 | 196 | 20 |
| 1.1/4 | 245 | 25 |

LIMITED PRODUCT WARRANTY

PT Guzzilla International (hereinafter called “Seller”) warrants its new equipment manufactured by Taguchi Industrial Co., Ltd. and / or PT Daisho Precision (hereinafter collectively called “Manufacturers”) and sold outside Japan, to be free, under normal use and service, of any defects in manufacture or materials for the following time periods, commencing on the date on which such equipment is invoiced to the original purchaser or the date on which such equipment is first put into service, whichever occurs first:

WITH RESPECT TO STRUCTURAL ELEMENTS: — 1 (One) year

WITH RESPECT TO ELECTRICAL COMPONENTRY: — 1 (One) year

**WITH RESPECT TO HYDRAULICAL COMPONENTRY (except as provided below):
— 1 (One) year**

provided that (1) Seller receives written notice of the defect within fourteen (14) days of its discovery and Buyer establishes that (i) the equipment has been maintained and operated within the limits of rated and normal usage; and (ii) the defect did not result in any manner from the intentional or negligent action or inaction by Buyer, its agents or employees and (2) a new machine registration certificate has been completed, signed and delivered to Seller within fourteen (14) days of the equipment’s “in-service” date. If requested by Seller, Buyer must return the defective equipment to manufacturing facility or other location designated by Seller, for inspection, and if Buyer cannot establish that conditions (1) (i) and (1) (ii) above have been met, then this warranty shall not cover the alleged defect. **Delivery inspection certificates are required to be completed, signed and delivered to Seller within one hundred twenty (120) days of the equipment’s “in-service” date and on file with Seller’s service department for warranty validation and processing.**

Seller’s obligation and liability under this warranty is expressly limited to, at Seller’s sole option, repairing or replacing, with new or remanufactured parts or components, any part, which appears to Seller upon inspection to have been defective in material or workmanship. Such parts shall be provided at no cost to the owner, FOB Seller’s parts facility. Freight charges are not covered. If requested by Seller, components or parts for which a warranty claim is made shall be returned to Seller at a location designated by Seller. All return freight charges are the responsibility of the buyer. All components and parts replaced under this limited product warranty become the property of Seller. This warranty shall be null and void if parts (including wear parts) other than genuine OEM Seller parts are used in the equipment. Accessories, assemblies and components included in the Seller equipment, which are not manufactured by Manufacturers, are subject to the warranty of their respective manufacturers. Normal maintenance, adjustments, or maintenance/wear parts, including without limitation cutting blade, chisel, crushing jaw, crushing teeth, friction plates, filters, are not covered by this warranty and are the sole maintenance responsibility of Buyer. This warranty shall be null and void if equipment is operated for military or criminal purpose or purpose of production of weapon, for the reason that Seller’s equipment is designed and produced for non-military purpose.

SELLER MAKES NO OTHER WARRANTY, EXPRESS OR IMPLIED, AND MAKES NO WARRANTY OF MERCHANTABILITY OR FITNESS FOR ANY PARTICULAR PURPOSE.

No employee or representative is authorized to modify this warranty unless such modification is made in writing and signed by an authorized officer of Seller.

Seller's obligation under this warranty shall not include any duty, taxes, environmental fees, including without limitation, disposal or handling batteries, petrochemical items, or any other charges whatsoever, or any liability for direct, indirect, incidental, or consequential damages. Improper maintenance, improper use, abuse, improper storage, operation beyond rated capacity, operation after discovery of defective or worn parts, accident, sabotage or alteration or repair of the equipment by persons not authorized by Seller shall render this warranty null and void. Seller reserves the right to inspect the installation of the product and review maintenance procedures to determine if the failure was due to improper maintenance, improper use, abuse, improper storage, operation beyond rated capacity, operation after discovery of defective or worn parts, accident, sabotage or alteration or repair of the equipment by persons not authorized by Seller.

NO TRANSFERABILITY OF WARRANTY: This warranty is limited to the original purchaser or original end-user if sold to a dealer, and is not assignable or otherwise transferable without the written agreement of Seller.

ITEMS NOT COVERED BY SELLER WARRANTY

The following items are **NOT** covered under the Seller Warranty (the following list is not exhaustive):

1. Filters, hydraulic oil, consumables items, shop supplies.
2. Items sold by any individual, corporation, partnership or any other organization or legal entity that is not an authorized dealer by Seller.
3. Inbound freight for replacement components or outbound freight for any part requested as a warranty return.
4. Components which are not manufactured by Manufacturers are not covered by Seller's warranty. Such components are covered only by the warranty, if any, that is provided by the manufacturer of such components. Such components may include, but are not limited to, engines, batteries, tires, customer-supplied products, generators/gensets.
5. Replacement of assemblies: Seller has the option to repair or replace any defective part or assembly. It is Seller's policy to refuse claims for the replacement of a complete assembly that is field repairable by the replacement or repair of defective part(s) within the assembly.

6. Normal Operational Maintenance Services and Wear Parts: Maintenance services and wear parts are excluded from warranty claims. Maintenance services and wear parts not covered include, but are not limited to, such items as: cutting blade, chisel, crushing jaw, crushing teeth, cutting blade, seals, hoses, friction plates, exterior coatings, proper tightening of bolts, nuts and fittings, adding or replacing fluids, adjustment of any kind, services supplies such as hard cleaners, towels and lubricants, inspections, diagnostic time, travel time.
7. **Transportation cost and/or damage:** Any damage caused by carrier handling is a transportation claim and should be filed immediately with the respective carrier.
8. **Deterioration:** Repairs, work required or parts exposed as the result of age, storage, weathering, lack of use, demonstration use, or use for handling of corrosive chemicals.
9. **Secondary Failures:** Should the owner or operator continue to operate a machine after it has been noted that a failure has occurred. Seller will not be responsible under the warranty for resultant damage to other parts due to that continued operation.

Workmanship of Others: Seller does not accept responsibility for improper installation or labor costs or costs of any kind from personnel other than personnel authorized by Seller.

Stop and Go Warranty: Seller does not recognize “Stop and Go” warranties.

Incidental or Consequential Damage: SELLER SHALL NOT BE LIABLE FOR ANY INCIDENTAL OR CONSEQUENTIAL DAMAGES OF ANY KIND, INCLUDING, BUT NOT LIMITED TO, LOST PROFITS, LOSS OF PRODUCTION, INCREASED OVERHEAD, LOSS OF BUSINESS OPPORTUNITY, DELAYS IN PRODUCTION, COSTS OF REPLACEMENT COMPONENTS AND INCREASED COSTS OF OPERATION THAT MAY ARISE FROM THE BEWACH OF THIS WARRANTY.

Customer’s sole remedy shall be limited to (at Seller’s sole option) repair or replacement of the defective part.

THIS WARRANTY IS EXPRESSLY IN LIEU OF AND EXCLUDES ALL OTHER WARRANTIES, EXPRESS OR IMPLIED (INCLUDING THE WARRANTIES OF MERCHANTABILITY AND FITNESS FOR A PARTICULAR PURPOSE) AND ALL OTHER OBLIGATIONS OR LIABILITY ON SELLER’S PART. THERE ARE NO WARRANTIES THAT EXTEND BEYOND THE LIMITED WARRANTY CONTAINED HEREIN. Seller neither assumes nor authorizes any other person to assume for Seller any other liability in connection with the sale of Seller’s equipment. This warranty shall not apply to any of Seller’s equipment of any part thereof which has been subject to misuse, alteration, abuse, negligence, accident, acts of God or sabotage. No action by any party shall operate to extend or revive this limited warranty without the prior written consent of Seller. In the event that any provision of this warranty is held unenforceable for any reason, the remaining provisions shall remain in full force and effect.

IN THE EVENT OF ANY BREACH OF THE WARRANTY BY SELLER, SELLER'S LIABILITY SHALL BE LIMITED EXCLUSIVELY TO THE REMEDIES (AT SELLER'S SOLE OPTION) OF REPAIR OR REPLACEMENT OF ANY DEFECTIVE EQUIPMENT COVERED BY THE WARRANTY. IN NO EVENT SHALL SELLER, OR ANY SUBSIDIARY OR DIVISION THEREOF BE LIABLE FOR INCIDENTAL, INDIRECT, CONSEQUENTIAL OR OTHER DAMAGES OR LOSSES RESULTING FROM A BREACH OF WARRANTY INCLUDING, WITHOUT LIMITATION, LABOR COSTS, LOSS OF USE OF OTHER EQUIPMENT, THIRD PARTY REPAIRS, LOST PROFITS, LOST TIME, TOWING OR HAULING OF EQUIPMENT, RENTAL COSTS, PERSONAL INJURY, EMOTIONAL OR MENTAL DISTRESS, IMPROPER PERFORMANCE OR WORK, PENALTIES OF ANY KIND, LOSS OF SERVICE OF PERSONNEL, OR FAILURE OF EQUIPMENT TO COMPLY WITH ANY FEDERAL, STATE OR LOCAL LAWS. The Seller's liability to the Buyer shall not in any event exceed the purchase price of the equipment, provided that nothing contained in this limited product warranty shall operate to exclude the Seller's liability for death or personal injury.

